

DANIA COLLECTION

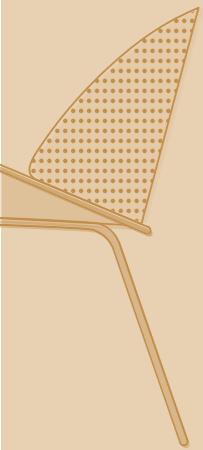
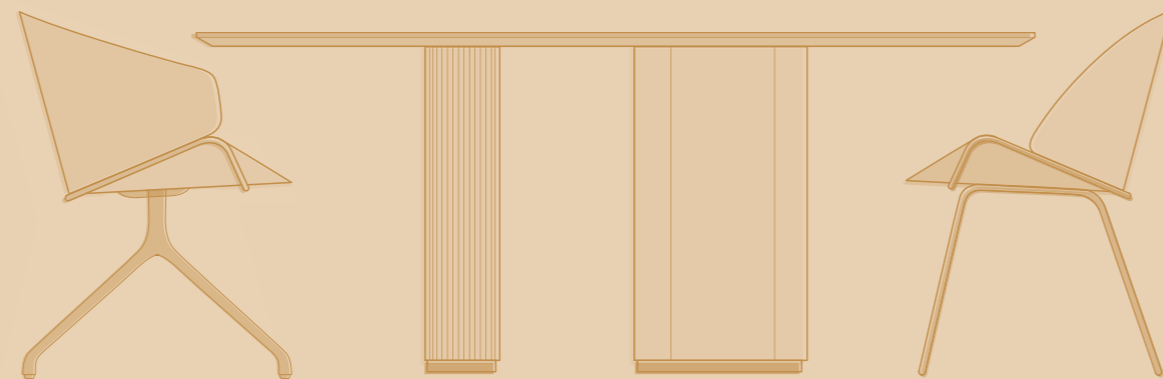
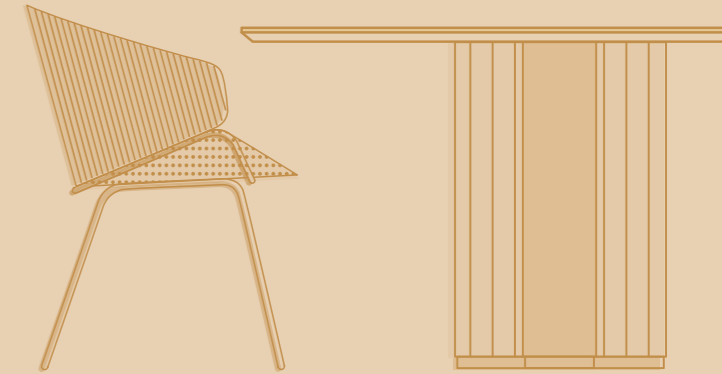
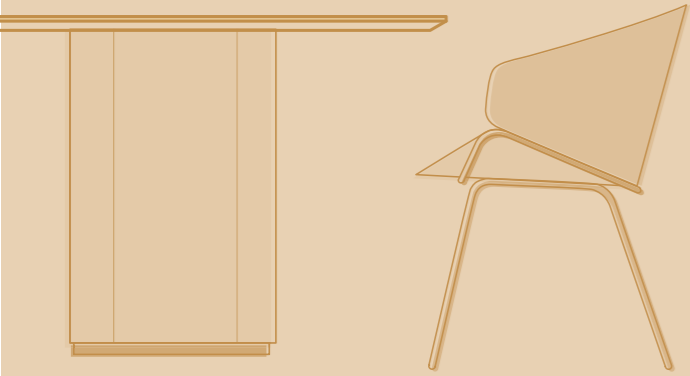

momocca

momocca

DYNAMIC CHAIRS & TABLES

Dania Collection



DANIA COLLECTION

Dania is inspired by the tides to present fully configurable chairs and tables. The calm appearance hides great strength and endurance inside.

The curved design of the chairs creates a wave between backrest and seat. Its finish navigates between natural oak or walnut wood, upholstered or milled panel. The tables are made of natural wood. The legs (transversal and longitudinal) and the curved edge stand out in their structure.

A collection that radiates delicate sophistication, but with great firmness. The perfect piece for home and contract interiors.

010

Serene · Comfortable · Dynamic

COLECCIÓN DANIA

Dania se inspira en las mareas para presentar sillas y mesas totalmente configurables. Apariencia sosegada cuyo interior esconde gran fuerza y resistencia.

En las sillas el diseño curvo crea una onda entre respaldo y asiento. Su acabado navega entre la madera natural de roble o nogal, tapizado o panel fresado. Las mesas se componen de madera natural. Destaca en su estructura sus patas (transversal y longitudinal) y el borde curvo.

Una colección que rebosa delicada sofisticación, pero de gran firmeza. La pieza perfecta para interiores hogar y contract.

LA COLLECTION DANIA

Dania s'inspire des marées pour présenter des chaises et des tables entièrement configurables. Une apparence calme dont l'intérieur cache une grande force et résistance.

Dans les chaises, le design courbé crée une vague entre le dossier et l'assise. Leur finition va du chêne naturel ou du noyer, au panneau rembourré ou fraisé. Les tables sont fabriquées en bois naturel. Les jambes (transversales et longitudinales) et le bord courbé se distinguent dans leur structure.

Une collection qui respire la sophistication délicate, mais avec une grande fermeté. La pièce parfaite pour les intérieurs de maisons et contract.

011





Model DAR-UBUS

RING · ARO · ANNEAU

The metal ring is one of the components providing resistance to Dania chairs. It reinforces the connection between the backrest and seat. Its curved design reminds us of a wave, rising delicately but firmly and elegantly.



El aro metálico es uno de los componentes que otorgan resistencia a las sillas Dania. Refuerza la unión del respaldo y el asiento. Su diseño curvo nos recuerda a una ola, alzándose delicada pero firme y elegante.

L'anneau métallique est l'un des composants qui confèrent aux chaises Dania leur solidité. Il renforce l'union du dossier et de l'assise. Son design courbé nous rappelle une vague, qui s'élève délicatement mais fermement et avec élégance.





BACKREST · RESPALDO · DOSSIER

Ergonomic design for maximum comfort. The backrest can be either fully upholstered or only on the inside, with wooden exterior. The latter option can incorporate the milled panel, emulating small waves. The curve is more intensely manifested if the armrests are integrated into the design.

Diseño ergonómico para la máxima comodidad. El respaldo puede ser tapizado por completo o solo en su interior con exterior de madera chapada. Esta última opción puede incorporar el panel fresado, emulando pequeñas ondas. La curva se manifiesta más intensamente si se opta por incorporar los reposabrazos integrados en el diseño.

Conception ergonomique pour un confort maximal. Le dossier peut être entièrement rembourré ou seulement à l'intérieur avec un extérieur en bois plaqué. Cette dernière option peut incorporer le panneau fraisé, émulant de petites vagues. La courbe se manifeste plus intensément si les accoudoirs sont intégrés au design.



SERENA

El diseño de Dania representa el alma y el carácter de las mareas: apariencia serena que esconde la fuerza en su interior. Esto la convierte en la solución ideal para integrarse en entornos cálidos y acogedores. Sus amplias posibilidades de configuración reposan en la idea de mostrar los materiales en su plenitud, mostrando un diseño honesto que transmite calma.

SEREINE

Le design de Dania représente l'âme et le caractère des marées : une apparence sereine qui cache la force intérieure. Cela en fait la solution idéale pour s'intégrer dans des environnements chaleureux et accueillants. Ses vastes possibilités de configuration sont basées sur l'idée de montrer les matériaux dans leur intégralité, en affichant un design honnête qui transmet le calme.

SERENE

Dania's design represents the soul and character of the tides: a serene appearance that hides the strength inside. This makes it the ideal solution to be integrated into warm and welcoming environments. Its wide configuration possibilities lie in the idea of showing the materials in their plenitude, displaying an honest design that exudes calmness.





Model DT120D60-WML · DCR-WBUS

TABLE · MESA · TABLE

La colección se compone, además, de elegantes mesas de madera natural, a escoger entre roble o nogal. Un diseño elegante en cuya composición destacan sus dos patas, una de orientación transversal y otra longitudinal. Sobre ellas reposa la superficie redondeada de borde biselado en madera chapada o porcelánico Dekton.

La collection comprend également d'élégantes tables en bois naturel, avec un choix de chêne ou de noyer. Un design élégant dans la composition duquel se détachent les deux pieds, l'un transversal et l'autre longitudinal. Sur elles repose la surface arrondie avec un bord biseauté en bois plaqué ou en porcelaine Dekton.

The collection is also composed of elegant natural wood tables, to choose between oak or walnut. An elegant design in whose composition two legs stand out, one transversal and the other longitudinal. On top of them rests the rounded surface with a bevelled edge in veneered wood or Dekton porcelain.



Models DARUBUS · DT200D100-WML · DARWBUS

CONFORTABLE

Dania se crea para que el confort sea uno de los pilares fundamentales de la colección. Todas sus opciones de configuración se basan en crear una experiencia basada en la comodidad del individuo. En las sillas se busca un diseño ergonómico para una correcta higiene postural. La mesa, por su parte, tiene un diseño amable y sin esquinas.

CONFORTABLE

Dania est créé pour faire du confort l'un des piliers fondamentaux de la collection. Toutes ses options de configuration sont fondées sur la création d'une expérience basée sur le confort de l'individu. Les chaises sont conçues de manière ergonomique pour une hygiène posturale correcte. La table, quant à elle, présente un design convivial sans angles.

COMFORTABLE

Dania is created to put comfort as one of the fundamental pillars of the collection. All its configuration options are based on creating an experience based on the individual's comfort. The chairs are ergonomically designed for correct postural hygiene. The table, meanwhile, has a friendly design without corners.





Model DAA-WBWS

LEGS · PATAS · PIEDS

Las sillas Dania ofrecen dos tipos de patas en su configuración: patas rectas, para un ambiente de hogar o patas de araña, más enfocados a espacios contract. En ambos casos, están realizadas en metal para una mayor resistencia y belleza.

Les chaises Dania offrent deux types de pieds dans leur configuration : des pieds droits, pour un environnement domestique ou des piétement araignée, plus orientés vers les espaces contractuels. Dans les deux cas, ils sont fabriqués en métal pour plus de solidité et de beauté.



Model DAR-MBWS

Dania chairs offer two types of legs in their configuration: straight legs, for a home environment or pyramid legs, more focused on contract spaces. In both cases, they are made of metal for greater strength and beauty.



DINÁMICA

El dinamismo de Dania permite a la colección adaptarse a la realidad del espacio, tanto en hogar como en contract. Las posibilidades de configuración van desde la selección de materiales y acabados, hasta la elección de elementos más concretos: tipo de respaldo, opción de reposabrazos en la silla y selección de varias dimensiones y tamaños en mesas.

DYNAMIQUE

Le dynamisme de Dania permet à la collection de s'adapter à la réalité de l'espace, dans les projets maison et contract. Les possibilités de configuration vont de la sélection des matériaux et des finitions au choix d'éléments plus spécifiques : le type de dossier, l'option d'accoudoirs sur la chaise et la sélection de différentes dimensions et tailles dans les tables.

DYNAMIC

The dynamism of Dania allows the collection to adapt to the reality of the space, both at residential and contract projects. The configuration possibilities range from the selection of materials and finishes, to the choice of more specific elements: type of backrest, option of armrests on the chair and selection of various dimensions and sizes in tables.





QUALITY IN EVERY DETAIL

Technical

CALIDAD EN CADA DETALLE

Cada detalle de Dania está perfectamente estudiado para que estética, confort y funcionalidad sean uno.

La composición, tanto de sillas como de mesas, se basa en la sinceridad de los materiales. A partir de ahí, se crea un diálogo entre madera natural, metal, tapizado y porcelánico unido a la curva.

En las sillas se observa más intensamente en el aro, que une el respaldo y el asiento. En las mesas a lo largo de la línea que bordea la superficie y el original diseño de sus patas.

QUALITÉ DANS CHAQUE DÉTAIL

Chaque détail de Dania est parfaitement étudié pour que l'esthétique, le confort et la fonctionnalité ne fassent qu'un.

La composition des chaises et des tables repose sur la sincérité des matériaux. À partir de là, un dialogue se crée entre le bois naturel, le métal, les tissus et la porcelaine combinés à la courbe.

Pour les chaises, ce phénomène s'observe plus intensément dans l'anneau qui relie le dossier et l'assise. Dans les tables, le long de la ligne qui borde la surface et le dessin original des pieds.

Compositions

QUALITY IN EVERY DETAIL

Every detail of Dania is perfectly studied so that aesthetics, comfort and functionality are one.

The composition of both chairs and tables is based on the sincerity of the materials. From there, a dialogue is created between natural wood, metal, upholstery, and porcelain combined with the curve.

In the chairs, this is most intensely observed in the ring that joins the backrest and seat. In the tables, along the line that borders the surface and the original design of the legs.

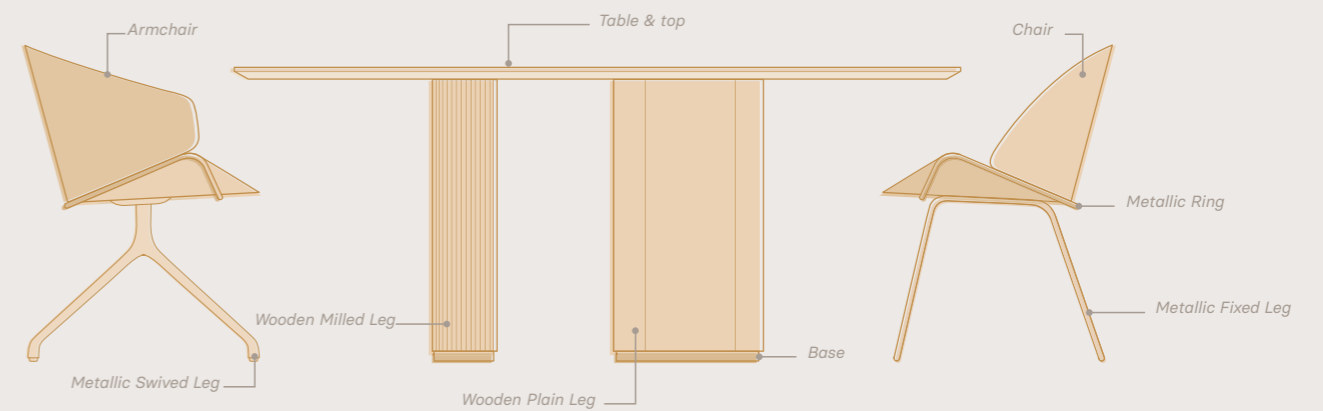

CREATE YOUR DANIA SYSTEM

Standard Compositions



CHAIR & ARMCHAIR

cm inches

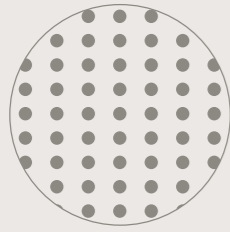

Upholstered
BACK & SEAT

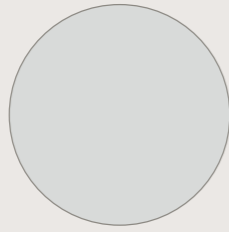

Wooden
BACK & SEAT

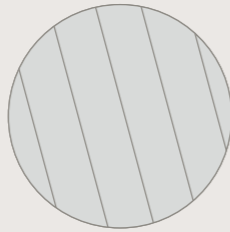

Milled Wood
BACK



56 22"



56 22"

CHAIR & ARMCHAIR · FIXED LEG

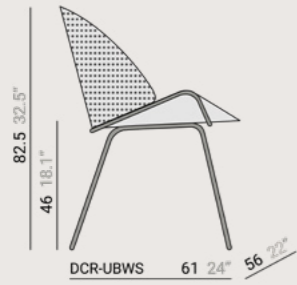

DCR-UBWS 61 24" 56 22"

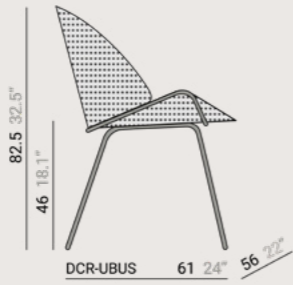

DCR-UBUS 61 24" 56 22"

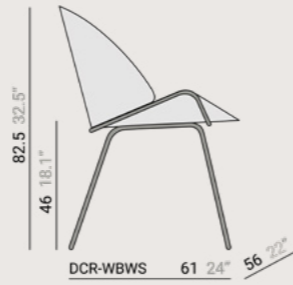

DCR-WBWS 61 24" 56 22"

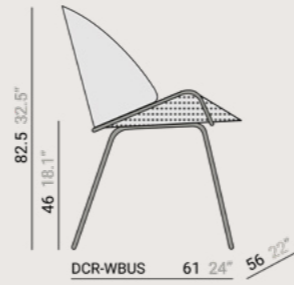

DCR-WBUS 61 24" 56 22"

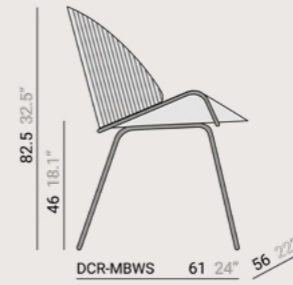

DCR-MBWS 61 24" 56 22"

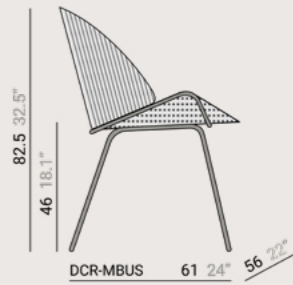

DCR-MBUS 61 24" 56 22"

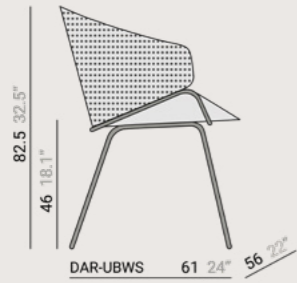

DAR-UBWS 61 24" 56 22"

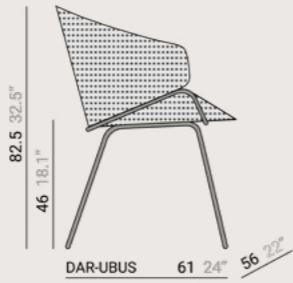

DAR-UBUS 61 24" 56 22"

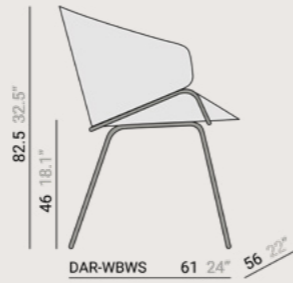

DAR-WBWS 61 24" 56 22"

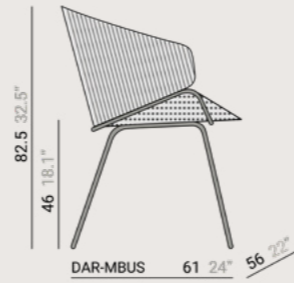

DAR-MBUS 61 24" 56 22"

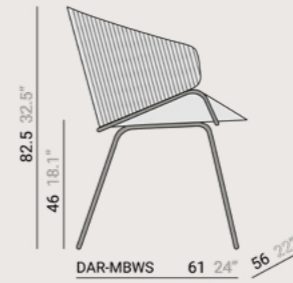

DAR-MBWS 61 24" 56 22"

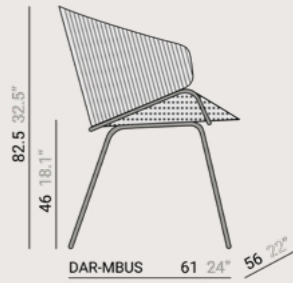

DAR-MBUS 61 24" 56 22"

CHAIR & ARMCHAIR · SWIVED LEG

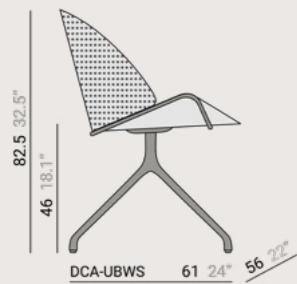

DCA-UBWS 61 24" 56 22"

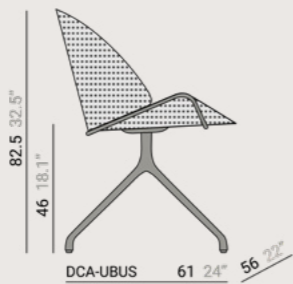

DCA-UBUS 61 24" 56 22"



DCA-WBWS 61 24" 56 22"

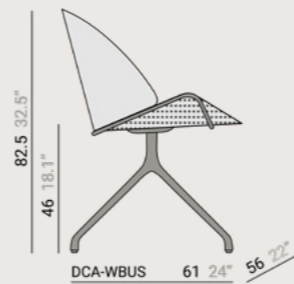

DCA-WBUS 61 24" 56 22"

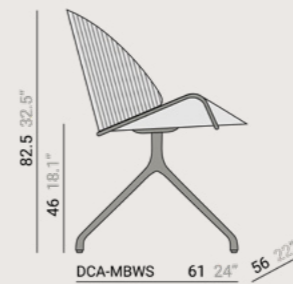

DCA-MBWS 61 24" 56 22"

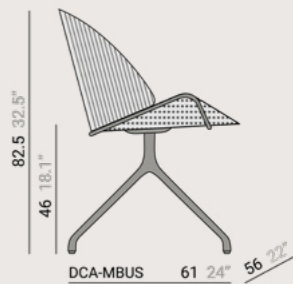

DCA-MBUS 61 24" 56 22"

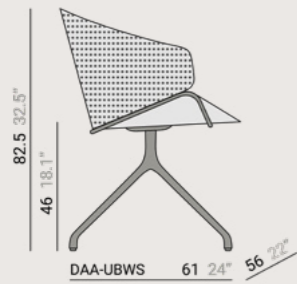

DAA-UBWS 61 24" 56 22"

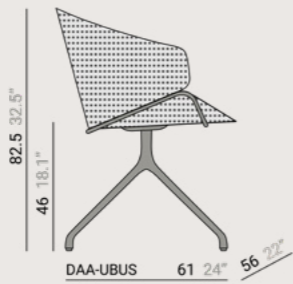

DAA-UBUS 61 24" 56 22"

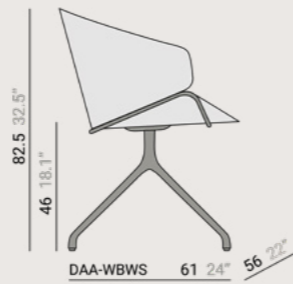

DAA-WBWS 61 24" 56 22"

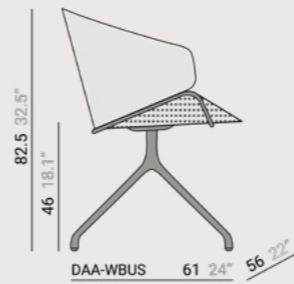

DAA-WBUS 61 24" 56 22"

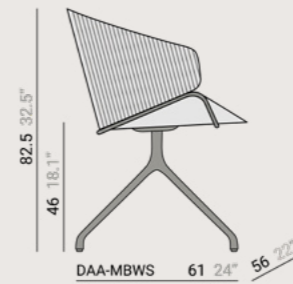

DAA-MBWS 61 24" 56 22"

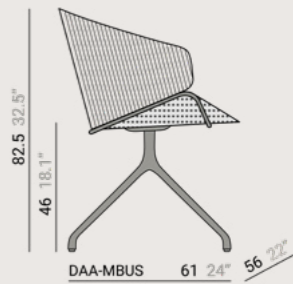

DAA-MBUS 61 24" 56 22"

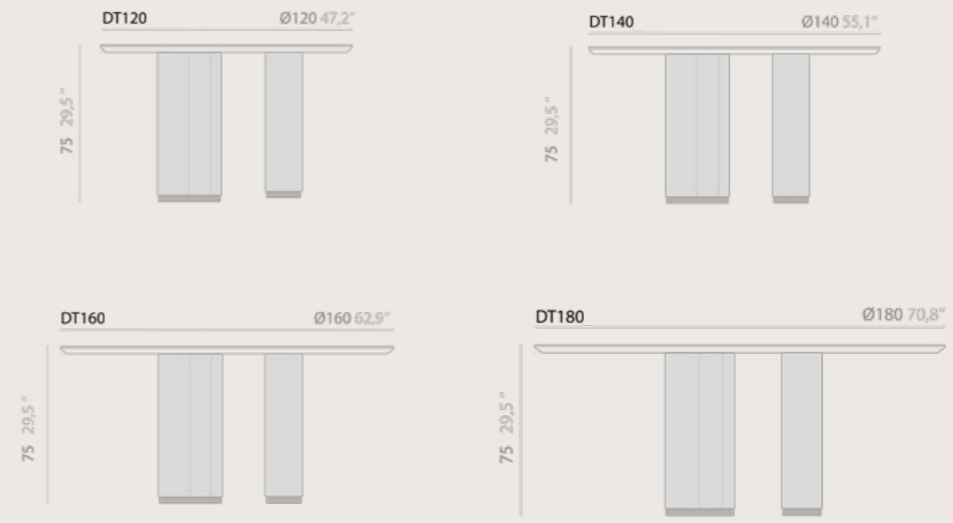
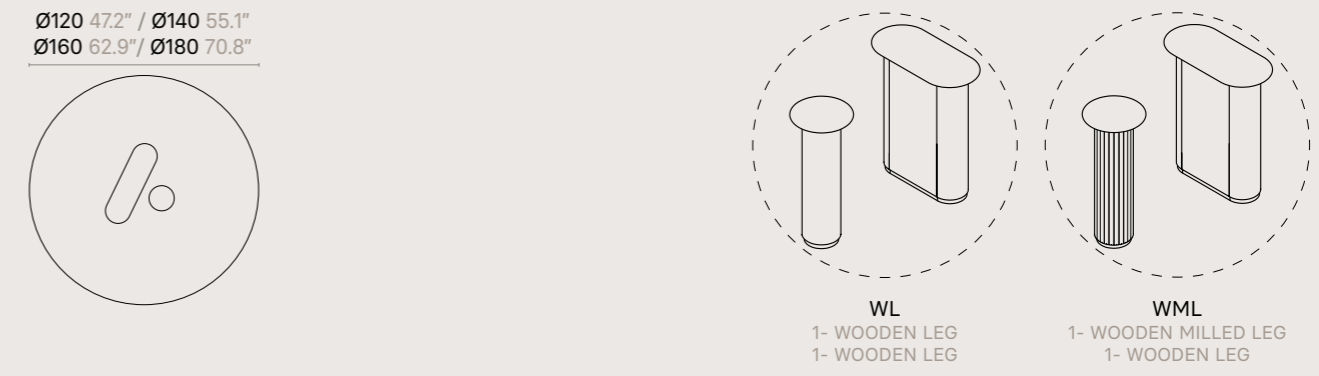
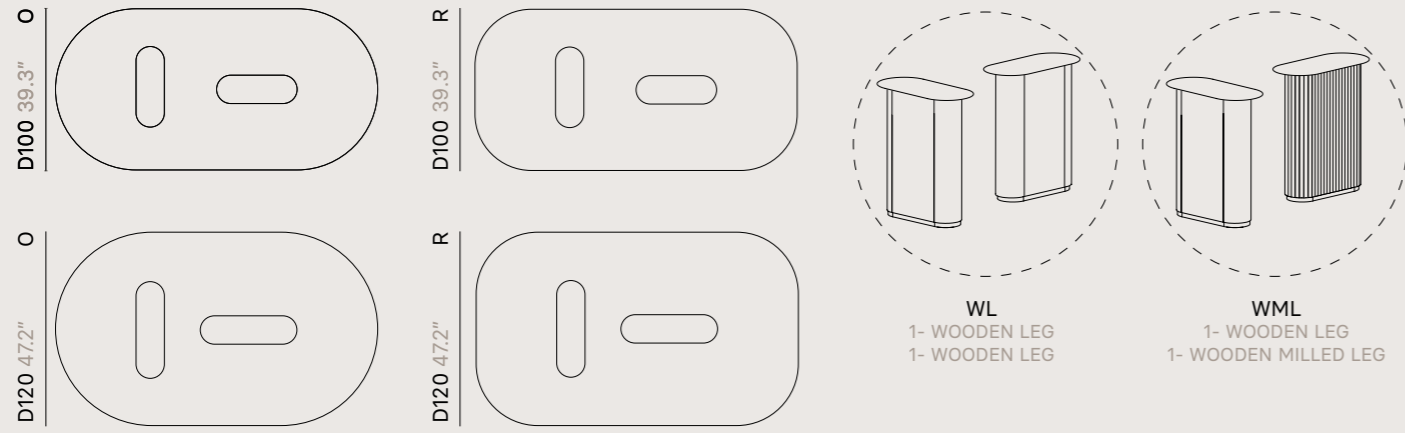

CONEXION
 Aviable in:
 Black
 White
 Stainless Steel

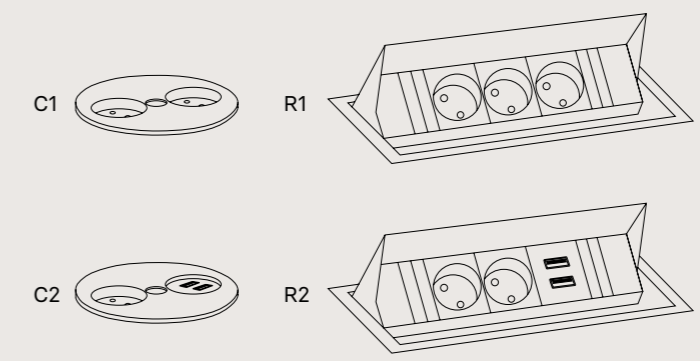

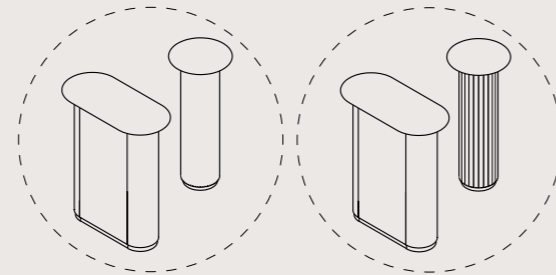

WL
1- WOODEN LEG
1- WOODEN LEG

WML
1- WOODEN LEG
1- WOODEN MILLED LEG

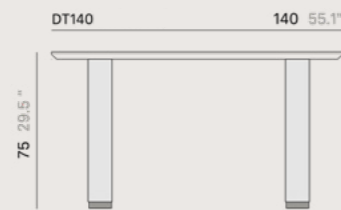
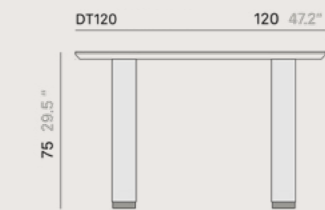

CONEXION
Available in:
Stainless Steel

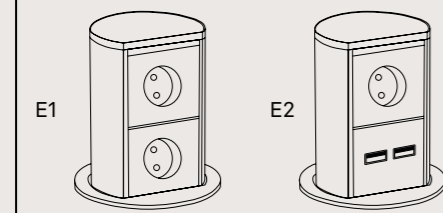

Available for all measures except for Round Tables.

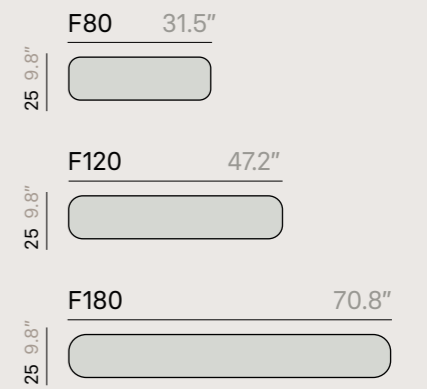
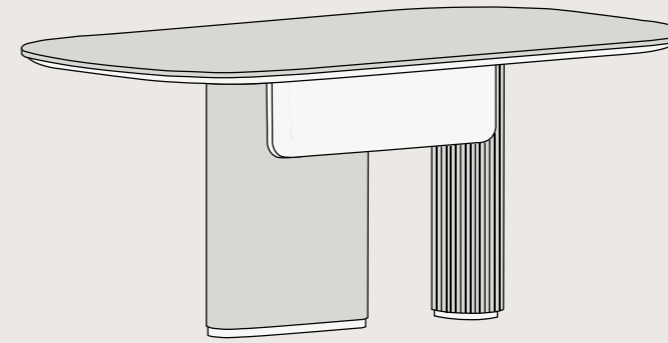

Creative Direction by Pablo Gironés Office.
Photography by Nudo Estudio.

Momocca Design, S.L. reserves the right to change, without previous notice, materials, covers, finishes and drawings of the products presented in this catalogue. The textures and colours of materials and finishes are indicative as they are depending on the tolerances of the printing process.

Momocca Design, S.L. se reserva el derecho de modificar, sin previo aviso, materiales, tejidos, acabados y dibujos de los productos presentados en este catálogo. Las texturas y colores de los materiales y acabados son indicativos dependiendo de las variaciones del proceso de impresión.

Momocca Design, S.L. se réserve le droit de modifier sans préavis, le matériaux, tissus, finitions et dessins des produits représentés dans ce catalogue. Les textures et les couleurs des matériaux et des finitions son à titre indicatif en fonction des variations du processus d'impression.

Parque Tecnológico de Paterna.
Av. Juan de la Cierva, 10 (P2-D1).
46980 Valencia (España)

+34 962 752 400
info@momocca.com
www.momocca.com