

MADE IN FLORENCE

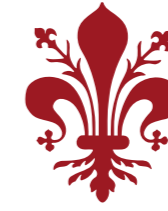

Nacque qui la lingua italiana e crebbe qui la tradizione espressiva dell'arte e della cultura.

Quando parliamo di arte e cultura pensiamo al bello, al lavoro, all'abilità, ai tempi dilatati, alla minuzia del segno, al tratto, ora immobile, ora vivo, ai colori caldi della terra bruciata, al rosso vermiglio, all'amore, alla forza, alla testimonianza di un trascorso vivo di creatività e passione.

L'ardore è intrinseco della gente di Florentia, tutti contro tutti, polemici di natura, di cuore, vivaci nella loro arroganza, liberi di pensiero, liberi di pensare una cosa e rinnegarla il giorno dopo, credere nelle proprie idee, oggi sue, domani non si sa, comandare se stessi, obbedire a nessuno, amare tutti, ma non per sempre.

La gente di questa terra è così, libera in ogni sua espressione, libera di essere libera.

*Here was born the Italian language and grew up the expressive tradition of art and culture.*

*When we talk about art and culture we think of the beautiful, the work, the ability, the strength, the love, the witness of a past full of creativity and passion.*

*Enthusiasm is proper to the people of Florence, with controversial nature, vivid in their arrogance, free of thought, they believe in their own ideas, obey anyone and loving everyone, but not always.*

*The people of this country are free in all its forms, free to be free.*



# Perché Poggesi

## Principalmente per una questione di stile.

La nostra azienda produce ombrelloni dal 1964 in costante crescita commerciale e sviluppo. In questi anni non abbiamo avuto il timore di sperimentare nuove soluzioni nel momento in cui l'ombrellone tradizionale incontrava la fine della sua evoluzione. Abbiamo compreso per primi l'importanza di avere piena libertà d'uso dello spazio sotto il tetto liberandolo dall'ingombro del palo. Così è nato l'ombrellone a palo laterale.

Abbiamo migliorato la manovrabilità sostituendo i meccanismi di apertura a cavo e carrucole con un sistema ad argano meccanico, il passo successivo è stato il movimento telescopico del tetto per evitare la rimozione degli arredi nella fase di chiusura e apertura.

L'Ombrellificio Poggesi conosce bene le sue potenzialità e la sua organizzazione ciò nonostante ha voluto sottoporsi all'esame di uno degli istituti di qualità più importanti in Europa per dare a tutta la sua clientela un'ulteriore prova della sua grande esperienza. Dall'Aprile 2010 l'azienda Ombrellificio Poggesi è certificata ISO 9001.

-----

## Mainly to a question of style.

*Our company produces umbrellas from 1964 in constant commercial growth and development. In these years, we didn't have the fear of experimenting new solutions when the traditional sun umbrella met the end of its evolution. We understood first the importance of having full freedom of using the space under the canopy without the overall dimension of the pole. So the lateral pole umbrella is born.*

*We have replaced the cable-mechanisms with a mechanical winch system. The next step was the telescopic movement to prevent the removal of the furniture in the closing and opening phase.*

*Ombrellificio Poggesi knows its potential and its organization and wanted to undergo the examination of one of the most important quality institutions in Europe to provide all its customers further evidence of its great experience.*

*Since April 2010, Ombrellificio Poggesi has certified the quality of its production with the ISO 9001 quality mark.*



# Team Poggesi

## Condividere un valore.

Siamo convinti che il valore aggiunto della nostra azienda sono le persone che ci lavorano.

Senza di loro non potremmo fare delle promesse.

Senza di loro non potremmo mantenerle.

Senza di loro è impossibile migliorare.

Per un collaboratore la motivazione è quella di vedere la propria azienda crescere, di poter svolgere bene il proprio lavoro, di poterlo ripagare con il suo operato.

Per questo riteniamo siano i protagonisti dello sviluppo dell'azienda perché ne condividono le strategie e gli obiettivi, a tutti i livelli, lavorando con passione e dedizione per mantenere le promesse fatte: è grazie a loro se abbiamo saputo evolverci e puntare su obiettivi di sviluppo sempre più ambiziosi.

Ciò che accomuna i componenti di questo Team è il saper "visualizzare" le cose belle che arriveranno, quelle che ci danno la motivazione per andare avanti e ci gratificano per l'impegno profuso.

Solo così possiamo ritenerci un'Azienda.

-----

## Share a value.

*We believe that the added value of our company are the people who work there.*

*Without them we could not make promises.*

*Without them we could not keep them.*

*Without them it is impossible to improve.*

*For a co-worker, the motivation is to see your company grow, to be able to perform well their work. For this reason, we think they are the protagonists of the development of the company because they share the strategies and objectives, working with passion and keep all promises: it is thanks to them that we have been able to evolve.*

*What unites the members of this team is the capacity to "see" the good things that will come, the ones that give us the motivation to going on and gratify us for our efforts. It's the only way to be a company.*

# Partners Poggesi

## Coinvolti é diferente.

Ci piace coinvolgere attivamente i nostri partners nello sviluppo della nostra produzione perché la loro esperienza non è importante: è necessaria.

Il loro coinvolgimento nella vita dell'azienda rappresenta un momento di crescita per noi perché interagire con idee ed esperienze dirette ci aiuta a colmare il distacco esistente tra produttore e cliente finale.

I nostri partners sono a conoscenza delle problematiche del cliente finale per cui la forza di questo vincolo è inscindibile per migliorare il nostro prodotto.

Ci piace immaginare questo come un legame a tre dove la posizione di privilegio è occupata dalla soddisfazione del cliente, perché consigliato da un buon rivenditore a cui proponiamo il prodotto migliore.

*"Dimmi e dimenticherò,  
mostrami e forse ricorderò,  
coinvolgimi e comprenderò"*

CONFUCIO

-----

## Involved is different.

*We like to actively involve our partners in the development of our production because their experience is not important: it is necessary.*

*Their involvement in the company of life is a time of growth for us because interact with ideas and direct experiences helps us to bridge the gap between producer and end customer.*

*We like to imagine this as a three-link where the privileged position is taken by the customer satisfaction as recommended by a good dealer who offer the best product.*

*"Tell me and I'll forget,  
show me and maybe I will remember,  
involve me and I'll understand"*

Confucius

# Vision Poggesi

## Saper fare cio' che sappiamo fare.

Sembra una frase rindondante e forse lo è, ma sintetizza l'essenza del nostro lavoro.

Nel corso degli ultimi 40 anni abbiamo perfezionato nei dettagli ogni singolo modello fino ad oggi dove possiamo consegnare un prodotto di alta qualità curato nei minimi particolari.

Noi consideriamo i nostri prodotti dei gioielli e come tali bisognosi di cura e manutenzione. Vogliamo trasmettere l'amore che noi dedichiamo ad essi a coloro che li acquisteranno per tanto impiegheremo molte energie a sviluppare una rete di manutentori qualificati al mantenimento in buona efficienza di un ombrellone Poggesi.

Non solo questo. La nostra *vision* si proietta al futuro, al connubio tra arte e tecnica, alla ricerca di nuovi materiali e nuove forme di ispirazione.

Per noi emozionarsi è emozionare.

-----

## Knowing how to do what we are able to do.

*Over the last 40 years we have perfected each model until today and now we can deliver a high quality product with meticulous attention to details.*

*We see our products as jewels and as such they need care and maintenance. We want to convey the love that we dedicate to them to those who purchase them and for this reason we will spend a lot of energy to develop a network of qualified maintenance personnel to maintain in good working a Poggesi umbrella. But not only this.*

*Our vision is projected to the future, at the combination of art and technology, at the research of new materials and new forms of inspiration.*

*To get excited and excites all.*



	nella pagina	
<b>PALO TELESCOPICO</b>	<b># 14 - # 30 - # 40</b>	<i>telescopic pole</i>
<b>PALO LATERALE</b>	<b># 56 - # 58 - # 64</b>	<i>side pole</i>
<b>PALO CENTRALE</b>	<b># 40 - # 102 - # 111</b>	<i>central pole</i>
<b>SOFFIETTO APPOGGIATO</b>	<b># 30 - # 51</b>	<i>soft bellow</i>
<b>SOFFIETTO RIALZATO</b>	<b># 60 - # 58</b>	<i>raised bellow</i>
<b>RESISTENZA AL VENTO</b>	<b># 14 - # 27</b>	<i>wind resistance</i>
<b>STECHE</b>	<b># 31</b>	<i>ribs</i>
<b>STECHE RINFORZATE</b>	<b># 22</b>	<i>reinforced ribs</i>
<b>CURVATURA STECCH</b>	<b># 110</b>	<i>bent ribs</i>
<b>COPRIBASE</b>	<b># 80 - # 85 - # 92</b>	<i>cover base</i>
<b>BASE CON CUSCINO</b>	<b># 53 - # 67</b>	<i>base with pillow</i>
<b>ATTACCO RIBALTABILE</b>	<b># 21</b>	<i>folding connection</i>
<b>TUBO DA INTERRARE</b>	<b># 45</b>	<i>underground tube</i>
<b>OMBRELLONE CHIUSO</b>	<b># 61</b>	<i>closed umbrella</i>
<b>INCLINAZIONE TETTO</b>	<b># 81</b>	<i>canopy tilting</i>
<b>ILLUMINAZIONE</b>	<b># 22 - # 34 - # 120</b>	<i>lighting</i>
<b>SEZIONE PALO</b>	<b># 130</b>	<i>pole section</i>
<b>FUORI STANDARD</b>	<b># 124</b>	<i>non standard</i>

**PAGE 14**  
MAGNUM

**PAGE 27**  
DEHOR

**PAGE 40**  
JOK

**PAGE 55**  
JUNIOR

**PAGE 65**  
SUMMER

**PAGE 76**  
KING &  
Baby KING

**PAGE 91**  
ONE

**PAGE 102**  
PARTY

**PAGE 111**  
BAY

**PAGE 122**  
ACCESSORI  
accessories

**PAGE 128**  
BASI  
bases

**PAGE 132**  
SCHEDE  
TECNICHE  
technical data sheet

**PAGE 142**  
DETTAGLI  
technical details

MISSION IS IMPORTANT



**Per noi tenere un orizzonte aperto alle nuove generazioni significa avere una visione prospettica agli occhi del futuro; la determinazione è la nostra energia. Rischiare un pò, guardare oltre, impegnarci a non rimanere immobili significa sentirsi in dovere di migliorare; con la presunzione di credere in qualche modo di essere un passo avanti.**

*For us, keep an open horizon to the new generations mean to have a perspective vision in the eyes of the future. Determining is our energy. Take small risk, looking ahead, do not stop; it means to feel in duty to improve ourselves with the presumption to believe in any way to be a step ahead.*

## PEOPLES OF FLORENCE

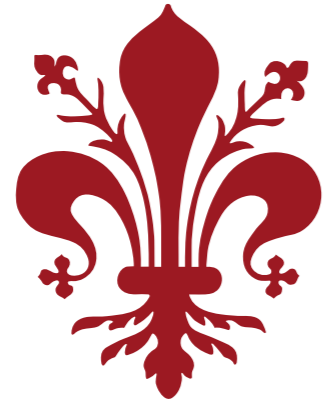

*Vid'io Fiorenza in sì fatto riposo,  
che non avea cagione onde piangesse;  
con queste genti vid'io glorioso  
e giusto il popol suo tanto, che il giglio  
non era ad asta mai posto a ritroso  
né per division fatto vermiglio*

**(Dante Alighieri, Divina Commedia, Paradiso, Canto XVI)**



MAGNUM  
DEHOR  
JOK

**palo telescópico**  
*telescopic pole*

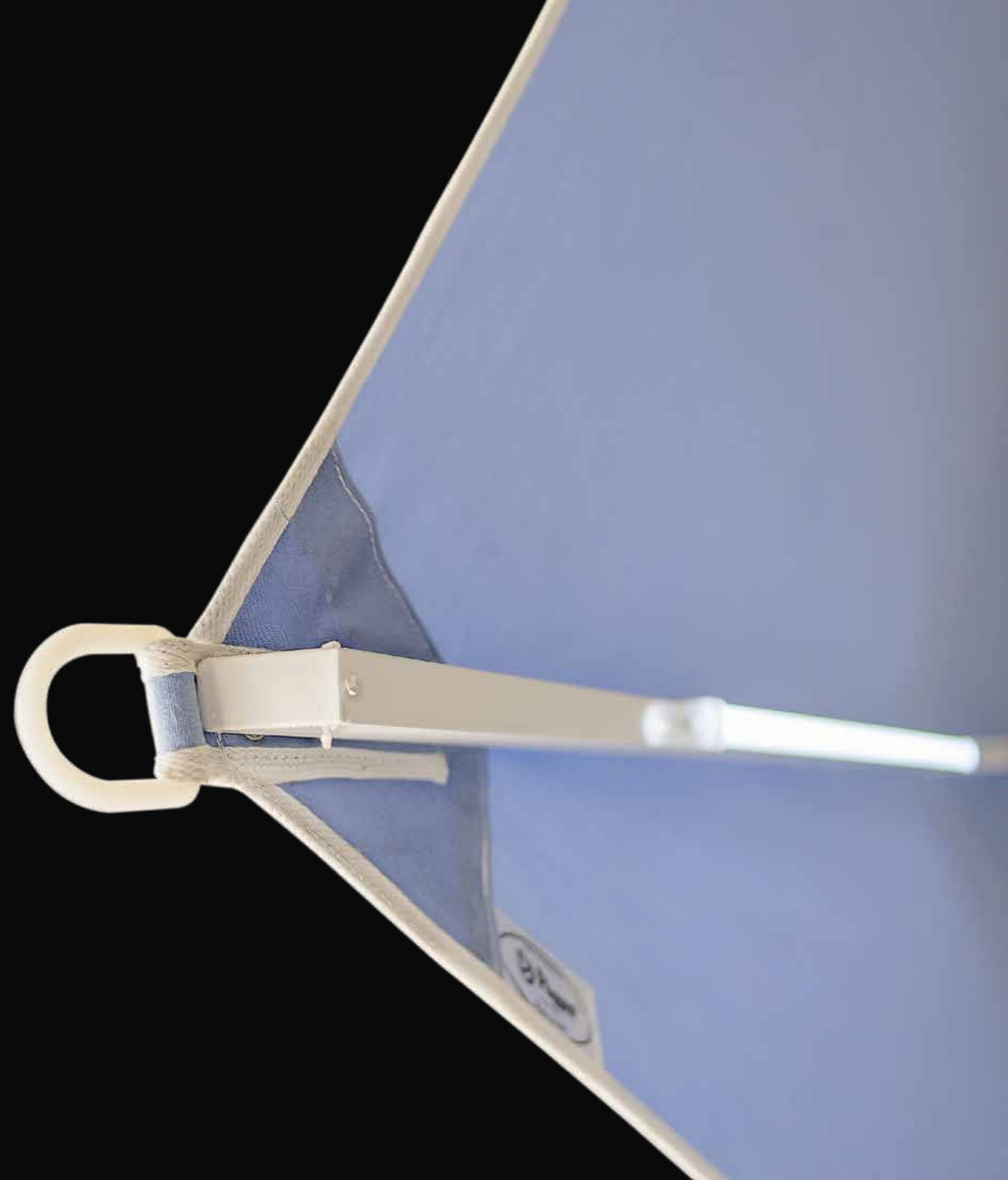



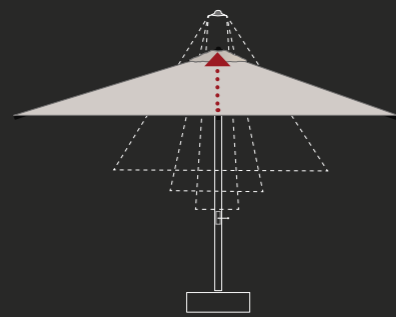

telescopic  
**TELESCOPICO**

# MAGNUM

Il più imponente della gamma telescopica, la sua massima area di copertura può raggiungere i 56 mq. con lati fino a 8 metri con la sua facilità d'uso imbattibile.

Apertura e chiusura meccanizzata rapida e sicura con moltiplicatore di giri, consente la non rimozione degli arredi sottostanti.

Potremo soddisfare le esigenze personali per quanto riguarda dimensioni e forma.

Resistente al vento fino a 60 km/h, scala Beufort 7.

*The most impressive of the telescopic range, its maximum coverage area can reach 56 square meters with sides up to 8 meters with its unbeatable easy operation system.*

*Quick and safe mechanized opening/closing system with worm screw, allows the non-removable of the furniture below.*

*We can meet personal needs in terms of size and shape. Wind resistant up to 60 km/h, scale Beufort 7.*







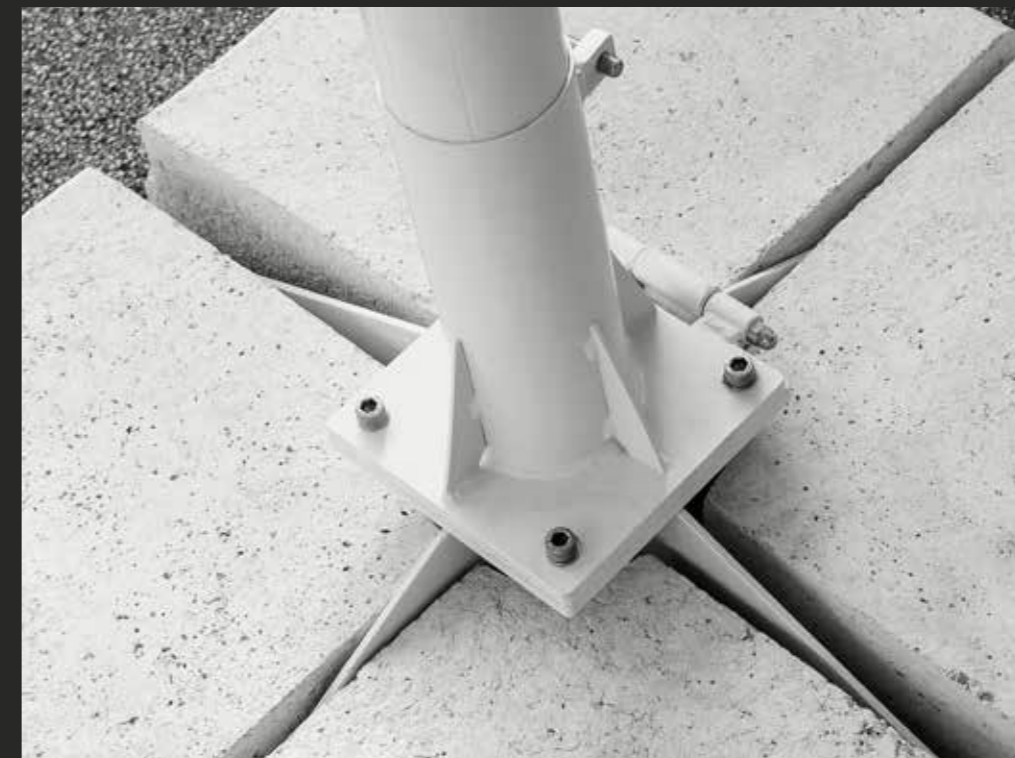

**Sollevare un ombrellone di 120 kg. non è una operazione semplice se non si adotta una tecnica particolare o un sistema meccanico esterno. Per questo abbiamo provveduto alla realizzazione di una base snodabile di 90° che permette l'innalzamento dell'ombrellone da terra con il minimo sforzo.**

*Raise a sun umbrella of kg.120 Is not simple if you don't adopt a particular technical or a mechanical system. For this reason, we have created an adjustable 90° base that allows to raise the umbrella with minimum effort.*

• FACILITA' DI MONTAGGIO E SMONTAGGIO / EASY INSTALLATION AND REMOVAL •





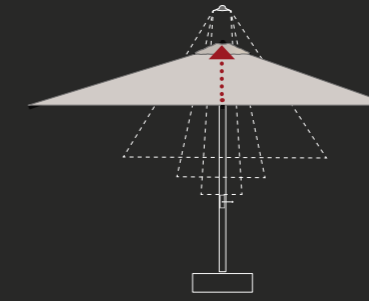

*telescopic*  
**TELESCOPICO**

## DEHOR

Questo ombrellone per grandi spazi convince per la sua efficienza e facilità di manovra.

Apertura e chiusura meccanizzata rapida e sicura con moltiplicatore di giri, consente la non rimozione degli arredi sottostanti.

Potremo soddisfare le esigenze personali per quanto riguarda dimensioni e forma.

Resistente al vento fino a 55 km/h, scala Beaufort 7.

*This umbrella for large spaces is impressive for its efficiency and easy operation.*

*Quick and safe mechanized opening/closing system with worm screw, allows the non-removable of the furniture below.*

*We can meet personal needs in terms of size and shape.*

*Wind resistant up to 55 km/h, scale Beaufort 7.*











DEHOR



**Il modello DEHOR come altri modelli della gamma Poggesi include nel palo in alluminio un'anima interna concentrica che racchiude il meccanismo telescopico. Le alette a raggiera presenti all'interno creano intercapedini da utilizzare per il passaggio di cavi elettrici.**

*The model dehor as other models of poggesi includes in the aluminum pole an internal concentric soul that contains the telescopic mechanism. The flaps inside create interspaces to be used for the passage of electrical cables.*

• PREDISPOSIZIONE PER IMPIANTO ELETTRICO / ARRANGED FOR ELETRICAL SUPPORT •





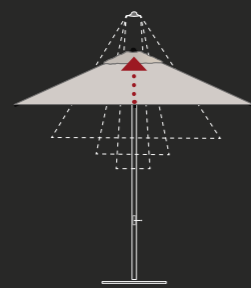

telescopic  
**TELESCOPICO**

JOK

Con maestosa leggerezza il più piccolo della gamma telescopica, robusto e resistente, estremamente versatile.

Apertura e chiusura meccanizzata rapida e sicura con moltiplicatore di giri, consente la non rimozione degli arredi sottostanti.

Potremo soddisfare le esigenze personali per quanto riguarda dimensioni e forma.

*With majestic lightness, the smallest of the telescopic range, strong and resistant, extremely versatile.*

*Quick and safe mechanized opening/closing system with worm screw, allows the non-removable of the furniture below.*

*We can meet personal needs in terms of size and shape.*





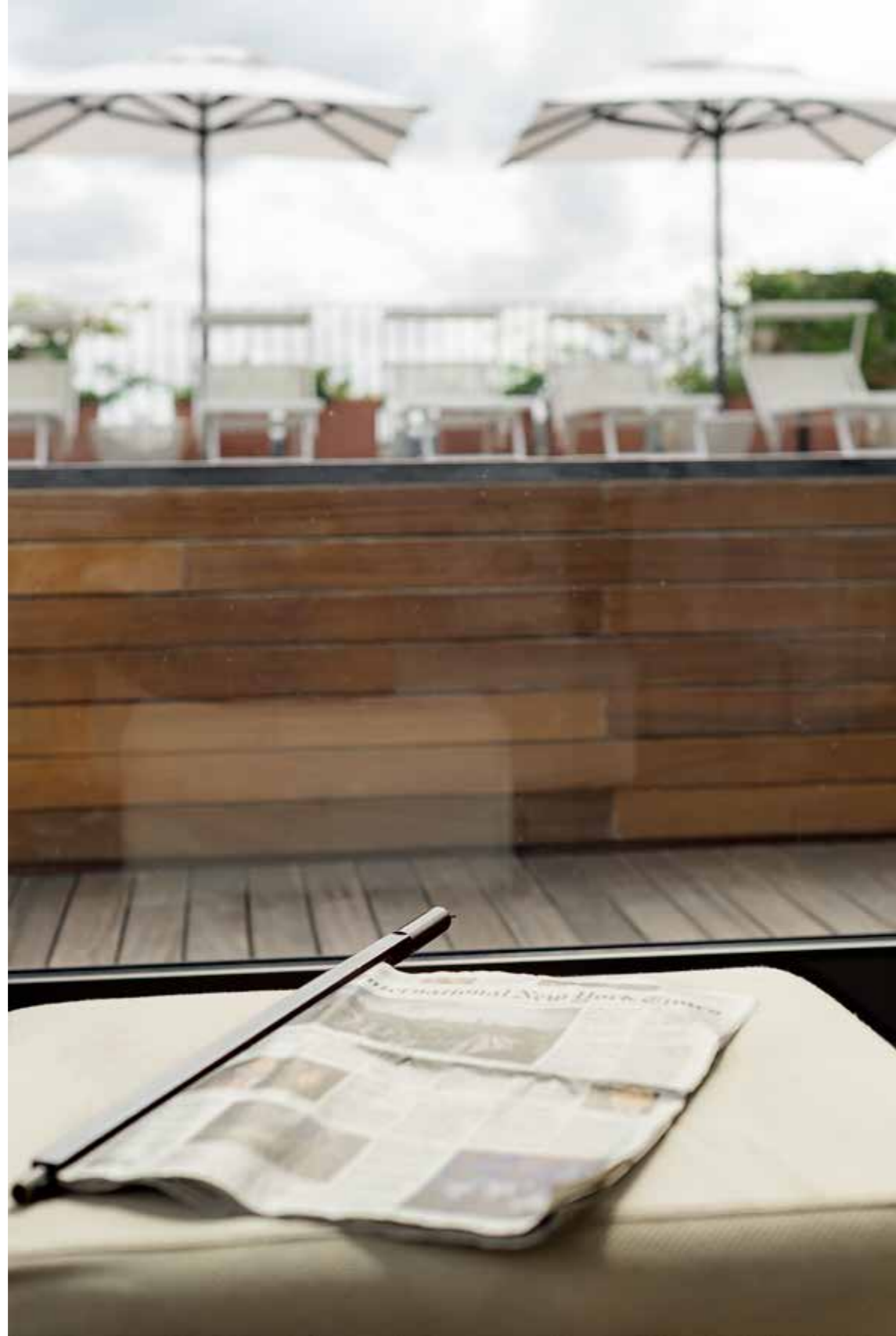









**I grandi spazi esigono la semplicità. Creare delle linee d'ombra continue tenendo in considerazione la riservatezza e la distanza aumenta la disponibilità ricettiva degli ospiti.**

*Big outdoor spaces require simplicity. Creating continue shadow's lines taking into consideration the confidentiality and the distance, increases guests comfort.*

• PARCO A TEMA / THEME PARK •



JOK

JUNIOR  
SUMMER

**palo laterale**  
*side pole*



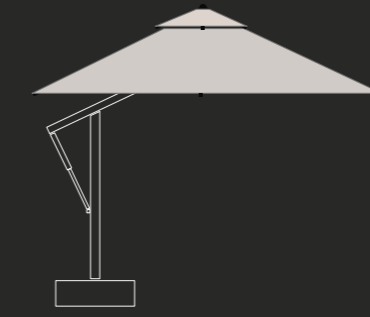

## JUNIOR

Nonostante il suo elevato livello tecnologico rimane il modello più semplice tra gli ombrelli a palo laterale.

Con azionamento a manovella, rettangolare o quadrato convince per funzionalità e design.

*In spite of its high technological level, the JUNIOR remains the simplest model among the side pole umbrellas.*

*With crank operation, rectangular or square, it impresses with functionality and design.*









**In alcuni casi lo spazio esterno è piuttosto ampio rispetto quello interno per cui adottare una soluzione di continuità tra dentro e fuori è un compromesso notevolmente vantaggioso.**

*In some cases the outdoor space is quite large respect to the inside space, so adopt a solution of continuity between inside and outside is a greatly favorable compromise.*

• SOLUZIONE E CONTINUITA' / SOLUTION AND CONTINUITY •



JUNIOR





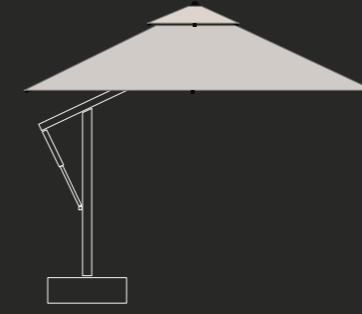

## SUMMER

Il modello SUMMER, erede del modello JUNIOR, non ha rivali tra rapporto qualità e prezzo nonostante le sue realizzazioni e finiture standard.

*The model SUMMER, heir of the JUNIOR, has no rivals between value and price despite its realizations and standard finishes.*

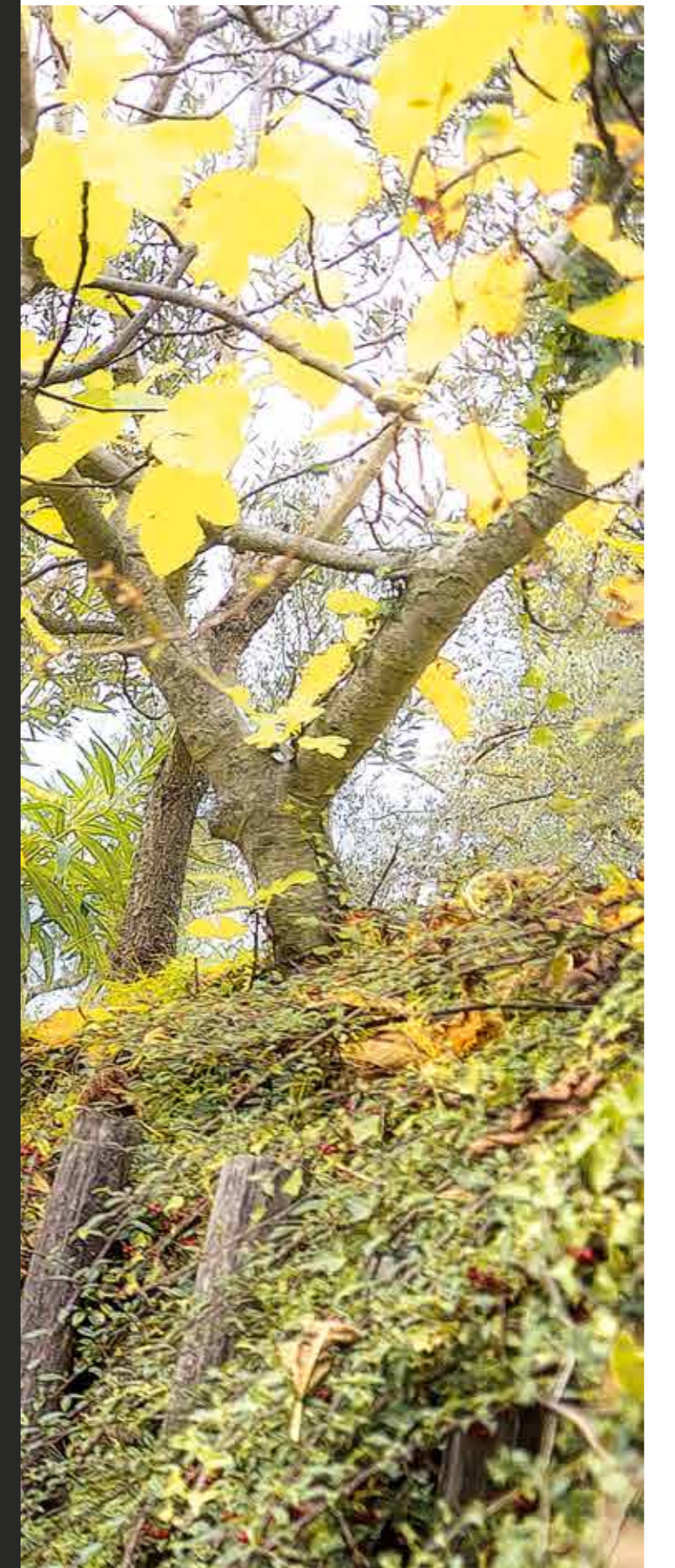



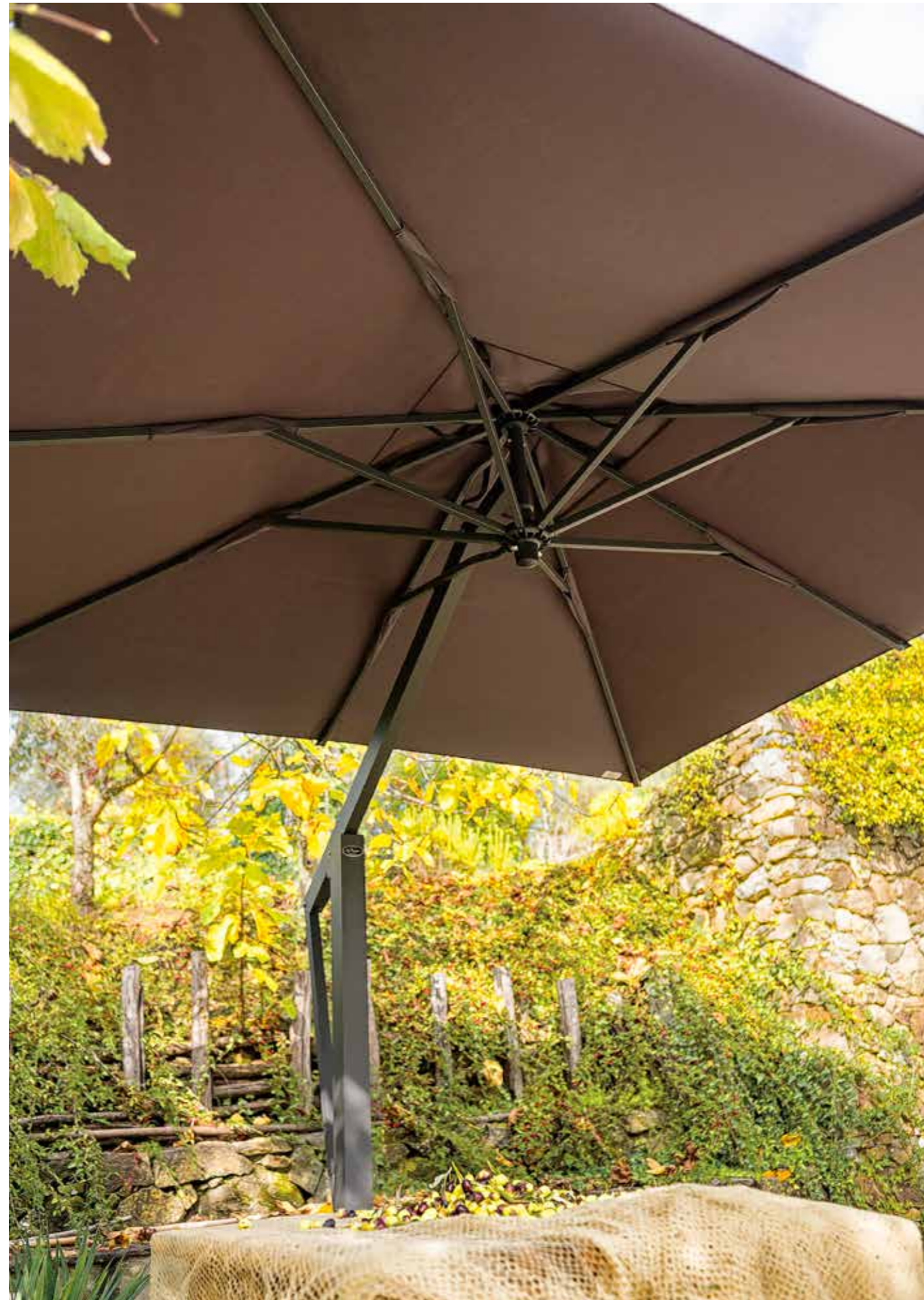







KING  
Baby KING

**palo laterale**  
*side pole*



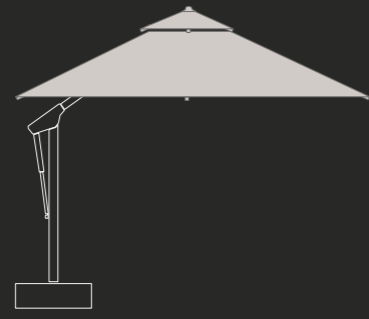

## KING & Baby KING

Questo modello fa grande onore al suo nome, grazie a un'estensione fino a 5 metri con struttura decentrata brevettata colpisce per la sua eleganza e i suoi dettagli che ne sottolineano l'estetica e la funzionalità.

Azionamento a manovella che permette molteplici funzioni come la rotazione a 360°, inclinazione e regolazione dell'altezza del telo, consente la non rimozione degli arredi sottostanti.

*This model makes great honor to his name, thanks to an extension of up to 5 meters with patented decentralized structure, it impresses with its elegance and its details that underline the aesthetics and the functionality.*

*Operation with handle crank that allows multiple functions such as 360° rotation, tilt and height adjustment of the canopy and allows the non-removal of the furniture below.*













**Un palazzo o una piazza è un bene comune a tutti e una degna accuratezza estetica ne valorizza l'armonia e il bel vivere. Creare una situazione confacente alle aspettative, proprie e altrui, è un importante opportunità per il tuo business.**

*A building or a square is a common good for all and a worthy aesthetic accuracy value the harmony and the good life. Create a situation that suited your and others expectations is an important opportunity for your business.*

• BUSINNES •



KING

## La fontana del **Porcellino**

Toccare il muso del Porcellino è diventato nel tempo sinonimo di buona sorte. Non solo per viaggiatori di tutto il mondo, ma anche per qualche fiorentino incline alla superstizione.

La leggenda popolare racconta che strofinando il muso, infilando una monetina in bocca se la stessa oltrepasserà la grata di scolo è segno di buon auspicio.

### *Porcellino's fountain*

*Touch the nose of the pig is become during the time the mean of good luck, not only for travelers from all over the world but also for some superstitious florentines.*



FLORENCEitaly

ONE

**palo laterale**  
*side pole*



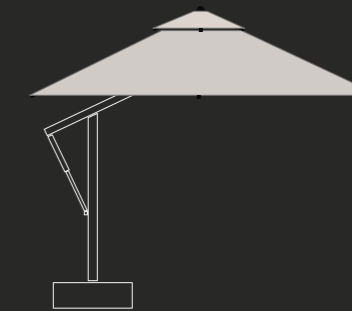

## ONE

Modello innovativo e funzionale, frutto di un attenta sperimentazione tecnologica e di design.

Colpisce per la sua facilità di utilizzo, grazie a un solo gesto raggruppa in un solo movimento la chiusura e l'inclinazione del telo.

-----  
*Innovative and functional model, the result of a careful technological and design experimentation.*

*It impresses with its ease of use thanks to a single gesture that brings together in one movement to the closing and the inclination of the canopy.*













**I colori accesi a volte sono un azzardo. In questo caso la location richiedeva colori vivaci in relazione alle opere di un noto artista. Il nostro assortimento tessuti copre una vasta varietà di colori.**

*Strong colours sometimes are a gambling but in this case the location required strong colors in connection with the works of a famous artist. Our range of fabrics cover a wide variety of colours.*

• COLORE TESSUTI / FABRICS COLOURS •





PARTY  
BAY

**palo centrale**  
*central pole*



## PARTY

Con dispositivo di apertura a carrucola e corda, classico, tradizionale e di facile utilizzo soddisfa pienamente tutte le esigenze.

*With opening/closing system with pulley and rope, this classical and traditional central pole umbrella is easy to use and fully meets all requirements.*









**Una disposizione in serie crea ambienti senza pareti leggeri e rilassanti. Questa tipo di sistemazione consente di predisporre un'area living per ospitare sia l'intimità di un incontro che la calca di una festa.**

*A serial disposition create areas without walls light and relaxing. This type of accommodation allows to create a living area to host a simple meeting or a party.*

• INTIMO COME UNA FESTA / INTIMATE AS A PARTY •





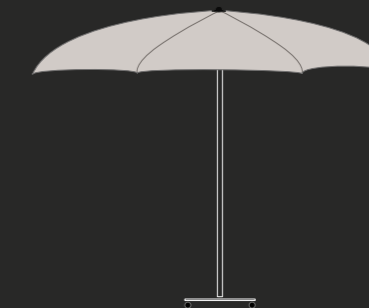

## BAY

La leggera ed elegante curvatura conferisce un'aura di modernità agli spazi esterni. Piccolo ma efficiente colpisce per la sua unicità e incredibile versatilità.

*The light and elegant bending, gives an aura of modernity to all the outdoor spaces. Small but efficient, it impresses with its unique and incredible versatility.*



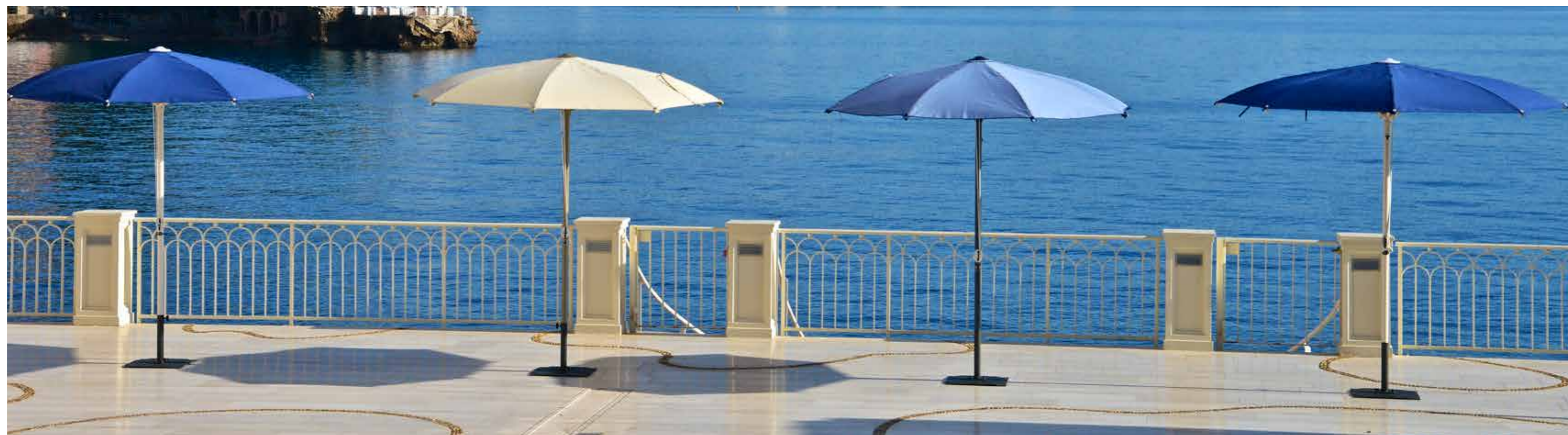





**Il legno ha il suo fascino, ma anche diverse problematiche. Il committente, in questo caso un noto hotel di Montecarlo, desiderava per il suo dehor un ombrello resistente con caldi colori del legno.**

*Wood has its charm but also several problems. This customer from montecarlo wished for his hotel a strong umbrella but with the warm colours of wood.*

• VERNICIATURA SIMIL-LEGNO / SIMIL WOOD PAINTING •



BAY





ACCESSORI  
*accessories*



faretto mobile 90°  
LED spotlight with joint

Watt	Volt
3	12



stecca LED a luce fredda con profilo rigido  
LED strip with rigid profile - cold light

cm.	Watt	Volt
50	9	12
100	18	12



ruota gemellata con rivestimento in gomma vulcanizzata e freno  
wheel covered in rubber with brake



asta di sostegno per chiusure laterali  
con attacco singolo da posizionare negli angoli  
single support rod for side walls



asta di sostegno per chiusure laterali con attacco a "U"  
(in caso di ombrelloni congiunti)  
support rod with "U" attachment for side walls



cuscinio per copribase in tessuto o eco-pelle  
pillow for coverbase in fabric or faux leather

cm.
70 x 70
90 x 90



cuscinio per copribase in tessuto o eco-pelle  
pillow for cover base in fabric or faux leather

cm.
117 x 54



custodia antigeliva in nylon  
nylon storage bag



chiusure laterali  
side walls



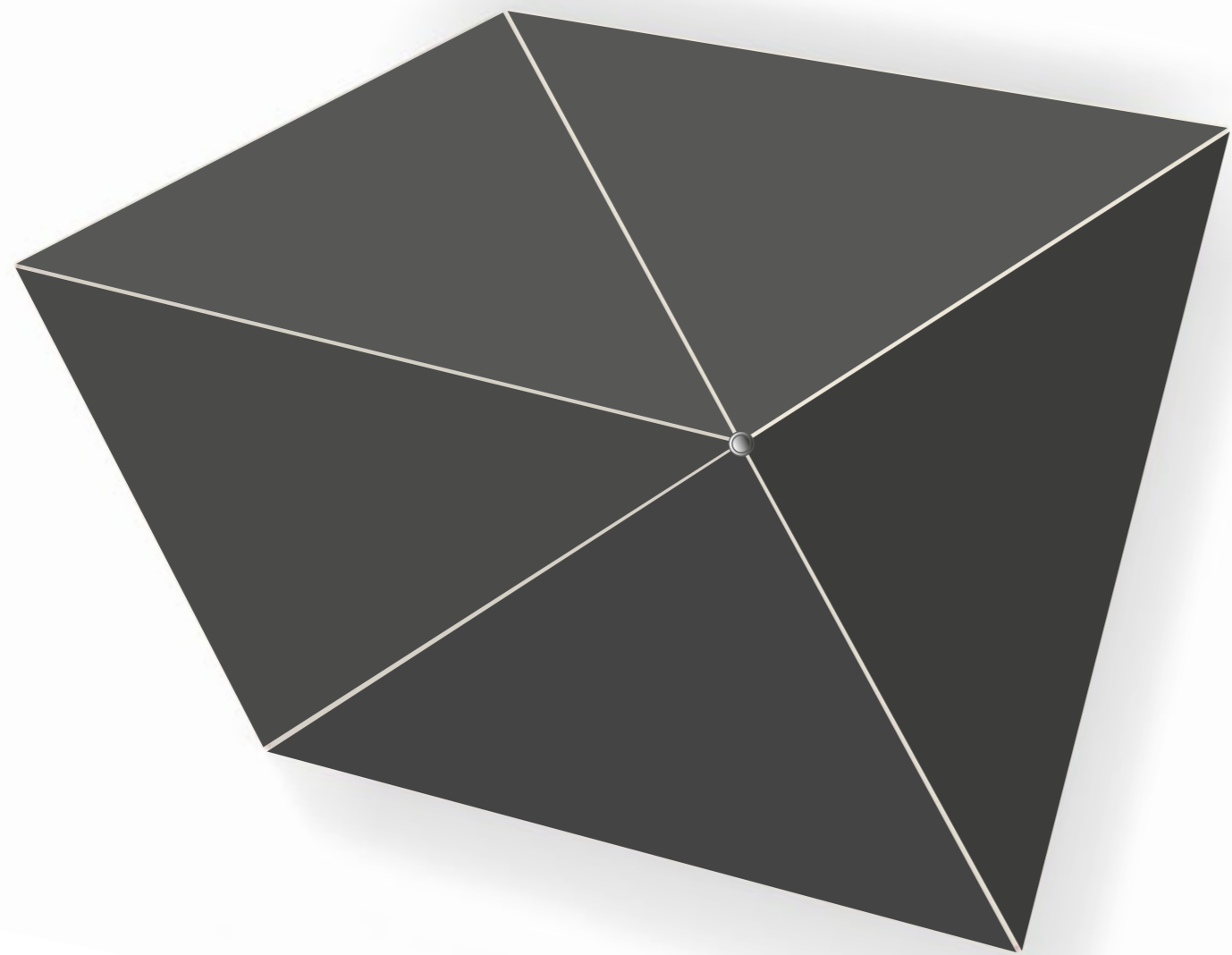

**Non è scontato che un ombrellone debba essere tradizionalmente quadrato o rettangolare. Con l'ausilio del nostro Ufficio Tecnico siamo in grado di progettare soluzioni trapezoidali o di forma asimmetrica in base alla superficie da coprire.**

*It's not true that an umbrella must be square or rectangular. With the help of our technical we can design trapezoidal or asymmetric solutions based on the surface that must be covered.*







BASI  
*bases*



base in ferro con set di 4 pesi in cemento  
iron base with set of 4 cement weights

	cm.	kg.	h. <sup>(*)</sup>
#1	70 x 70	160	20
#2	90 x 90	263	20



base in ferro con set di 8 pesi in cemento  
iron base with set of 8 cement weights

	cm.	kg.	h. <sup>(*)</sup>
#3	90 x 90	398	35



base in ferro con attacco ribaltabile  
iron base with retractable female connector

	cm.	kg.	h. <sup>(*)</sup>
#4	90 x 90	285	20



base in ferro con set di 4 pesi in cemento  
iron base with set of 4 cement weights

	cm.	kg.	h. <sup>(*)</sup>
#5	70 x 70	160	20



base in ferro con piastrelle in ciottolo  
iron base with pebble tiles

	cm.	kg.	h.
#6	54 x 117 x 0,5	153	11



base in ferro con piastrelle in ciottolo  
iron base with pebble tiles

	cm.	kg.	h.
#7	87 x 87 x 0,5	188	11



base in ferro con piastrelle in ciottolo  
iron base with pebble tiles

	cm.	kg.	h.
#8	107 x 107 x 0,5	280	11



base in ferro da fissare al suolo  
iron base for ground fixing

	cm.	kg.
#9	25 x 25 x 0,8	10

(\*) Altezza senza piedini regolabili / height without adjustable feet

	MAGNUM	DEHOR	JOK	KING	Baby KING	ONE	SUMMER	JUNIOR	PARTY	BAY
#1	-	-	-	-	•	•	-	•	-	-
#2	-	-	-	•	•	•	-	•	-	-
#3	-	-	-	•	•	-	-	-	-	-
#4	•	•	-	-	-	-	-	-	-	-
#5	-	-	•	-	-	-	-	-	•	•
#6	-	-	-	-	-	•	•	•	-	-
#7	-	-	-	-	-	-	•	-	-	-
#8	•	•	-	-	-	-	-	-	-	-
#9	•	•	-	-	-	-	-	-	-	-
#10	-	-	-	•	•	•	-	•	-	-
#11	•	•	-	-	-	-	-	-	-	-
#12	-	-	•	-	-	-	-	-	•	•
#13	-	-	•	-	-	-	-	-	•	•
#14	-	-	-	•	•	•	•	•	-	-
#15	-	-	-	•	•	•	•	•	-	-
#16	-	-	•	-	-	-	-	-	•	•
#17	-	-	-	-	-	•	•	•	-	-
#18	-	-	•	-	•	•	-	•	•	•
#19	•	•	-	•	•	•	•	•	-	-
#20	•	•	-	-	-	-	-	-	-	-



copribase  
base cover

	cm.	kg.	h.
#17	117 x 54	5	21
#18	70 x 70	5	21
#19	90 x 90	8	21
#20	107 x 107	12	21



base in ferro da fissare al muro  
iron base for wall fixing

	cm.	kg.
#10	25 x 25 x 0,8	20



tubo da interrare  
ground-fixed tube

	cm.	kg.
#11	25 x 25 x 0,8	12



base in ferro  
iron base

	cm.	kg.
#12	50 x 50	16



base in cemento  
cement base

	cm.	kg.
#13	Ø 60	41



base in ferro da avvitare al suolo  
iron base for ground fixing

	cm.	kg.
#14	25 x 25 x 0,8	5



tubo da interrare  
iron base for ground fixing

	cm.	kg.
#15	Ø 6,8	6



tubo da interrare  
iron base for ground fixing

	cm.	kg.
#16	Ø 50-60	5

## PALO / pole



sezione palo  
section of the pole

**MAGNUM**



sezione palo  
section of the pole

**DEHOR**



sezione palo modello KING  
section of the pole model KING

**KING**



**Alcuni modelli adottano pali con intercapedine. Oltre ad una maggiore rigidità le intercapedini permettono il passaggio del cablaggio elettrico.**  
*Some models have poles with interspace. In addition to greater stiffness interspaces allow the passage of electrical cables.*

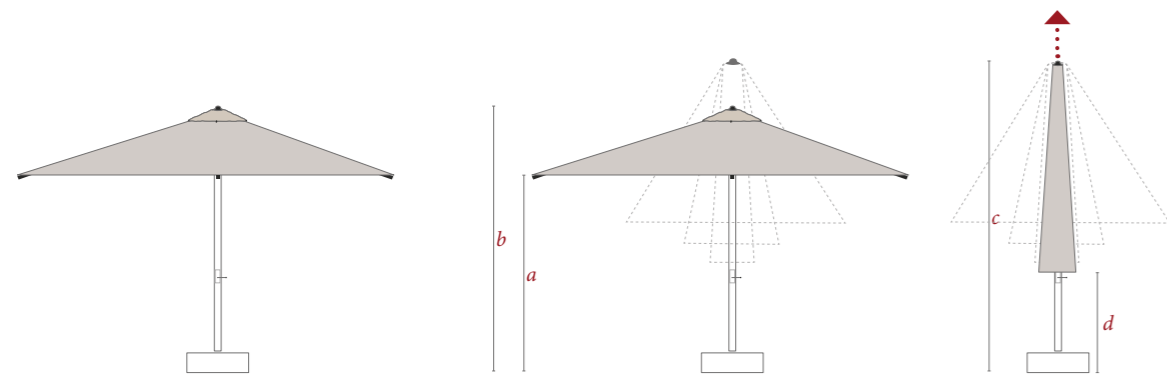

MODELLO	cm.	a	b	c	d
MGL5050	500 x 500	260	345	480	110
MGL5555	550 x 550	260	345	480	90
MGL6060	600 x 600	260	370	520	95
MGL6565	650 x 650	260	380	530	70
MGL7070	700 x 700	265	390	580	80
MGL7575 (*)	750 x 750	255	390	580	45
MGL5545	550 x 450	260	340	450	90
MGL6040	600 x 400	260	345	450	90
MGL6050	600 x 500	260	360	500	100
MGL6545	650 x 450	260	350	500	100
MGL6555	650 x 550	260	360	505	80
MGL7050	700 x 500	260	360	505	75
MGL7060	700 x 600	260	380	550	85
MGL8060 (*)	800 x 600	260	385	570	65
MGLd65	Ø 650	260	360	480	150
MGLd70	Ø 700	260	360	500	120
MGLd75	Ø 750	260	370	510	130
MGLd80	Ø 800	260	380	530	125

misure INDICATIVE espresse in cm. su qualsiasi base e tubo da interrare e base 25x25.

(\*) per queste misure su qualsiasi base + 20 cm.

dalla misura 600x600 per una maggiore stabilità si consiglia il tubo da interrare o la base 25x25.

APPROXIMATE measures in cm. on any bases, underground tube or base 25x25.

(\*) on any base + 20 cm.

for sizes up to 600x600 we suggest to use or the underground tube or the base 25x25 for ground fixing.

MANTOVANA / VALANCE



predisposizione chiusure laterali  
equipped for side wall fitting

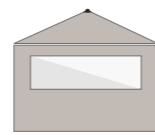

posizione del palo | pole position

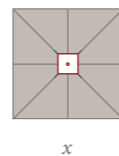

unione teli | canopy junction

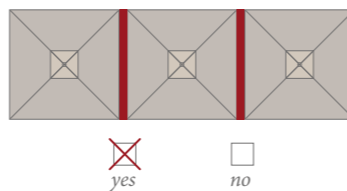

soffietto appoggiato | soft bellow

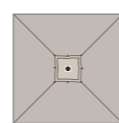

NON necessaria la rimozione arredi | NO furniture removal

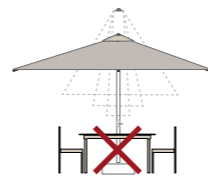

rotazione | rotation

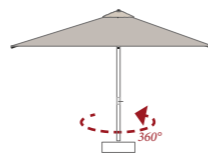

struttura predisposta per impianto elettrico  
provided for electrical support



resistenza al vento fino a 60 kmh.,  
wind resistant up to 60 km/h



BEUFORT 7

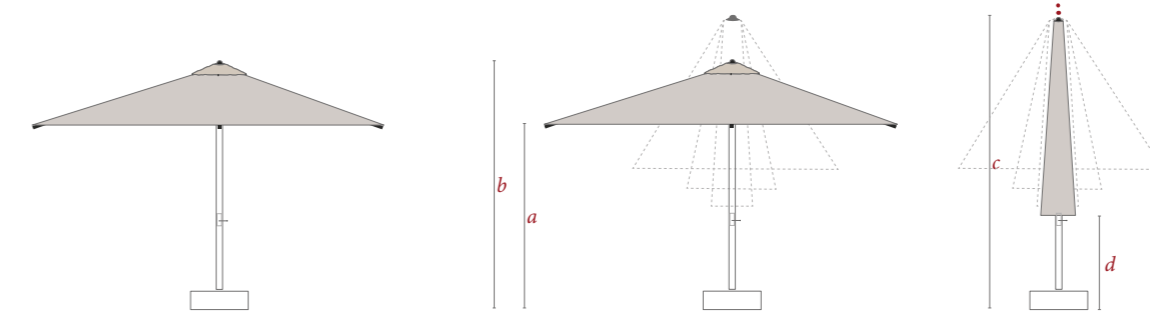

MODELLO	cm.	a	b	c	d
MDH3535	350 x 350	240	300	400	150
MDH4040	400 x 400	245	320	425	140
MDH4545	450x450	250	325	435	120
MDH5050	500 x 500	255	340	465	110
MDH5555	550 x 550	255	340	475	85
MDH6060	600 x 600	245	340	485	60
MDH4030	400 x 300	240	300	410	150
MDH4535	450 x 350	245	320	425	140
MDH4540	450 x 400	250	320	430	130
MDH5035	500 x 350	250	325	430	120
MDH5040	500 x 400	250	325	430	110
MDH5545	550 x 450	255	340	460	100
MDH6040	600 x 400	260	345	445	85
MDH6045	600 x 450	260	345	465	90
MDH6050	600 x 500	250	345	485	90
MDHd45	Ø 450	250	315	405	170
MDHd50	Ø 500	250	320	410	160
MDHd55	Ø 550	250	330	420	145
MDHd60	Ø 600	255	340	450	140

misure INDICATIVE espresse in cm. su qualsiasi base, tubo da interrare e base 25x25.

APPROXIMATE measures in cm. on any bases, underground tube or base 25x25.

MANTOVANA / VALANCE



predisposizione chiusure laterali  
equipped for side wall fitting

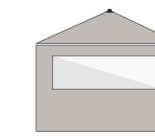

posizione del palo | pole position

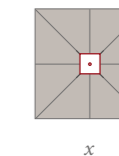

unione teli | canopy junction

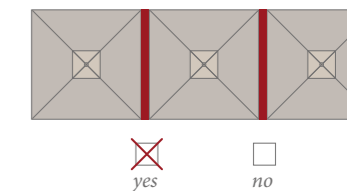

soffietto appoggiato | soft bellow

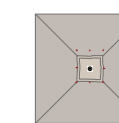

NON necessaria la rimozione arredi | NO furniture removal

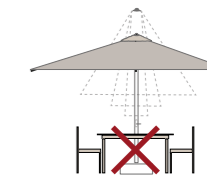

rotazione | rotation

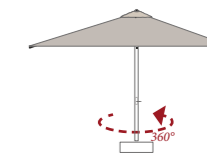

struttura predisposta per impianto elettrico  
provided for electrical support



resistenza al vento fino a 55 kmh.,  
wind resistant up to 55 km/h



BEUFORT 7

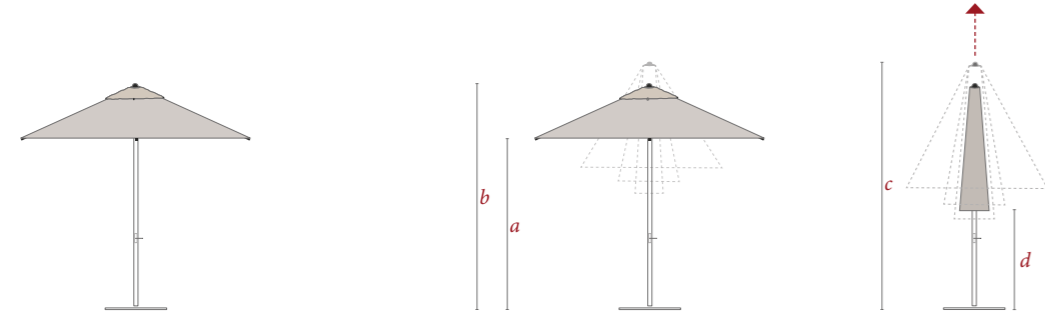

	MODELLO	cm.	a	b	c	d
	GIK3030	300 x 300	240	290	350	140
	GIK3535	350 x 350	240	300	360	120
	GIK4040	400 x 400	255	320	370	90
	GIK4545	450x450	260	340	380	80
	GIK4030	400 x 300	240	290	350	100
	GIK4535	450 x 350	260	320	370	85
	GIKd35	Ø 350	240	285	330	150
	GIKd40	Ø 400	240	295	355	150
	GIKd45	Ø 450	245	300	380	140
	GIKd50	Ø 500	250	305	390	140

misure INDICATIVE espresse in cm. su qualsiasi base e tubo da interrare.  
APPROXIMATE measures in cm. on any bases or underground tube.

MANTOVANA / VALANCE



predisposizione chiusure laterali  
equipped for side wall fitting

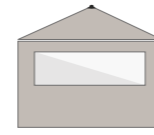

posizione del palo | pole position

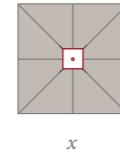

unione teli | canopy junction

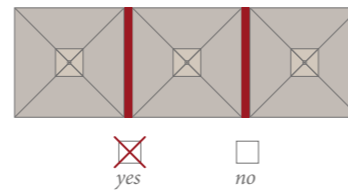

soffietto appoggiato | soft bellow

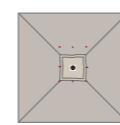

NON necessaria la rimozione arredi | NO furniture removal

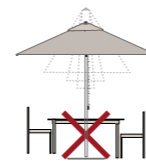

rotazione | rotation



struttura NON predisposta per impianto elettrico  
NOT provided for electrical support

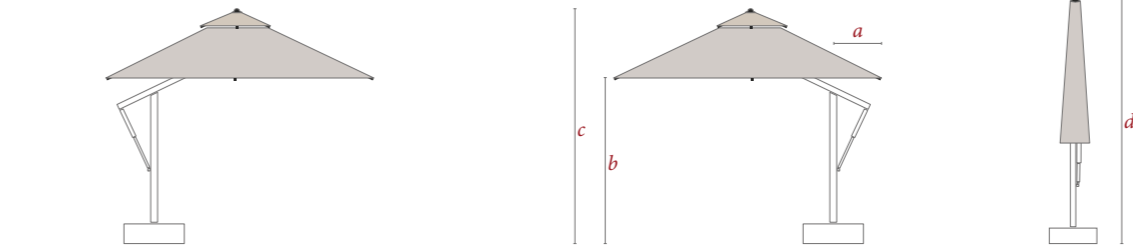

	MODELLO	cm.	a	b	c	d
	GJG2525	250 x 250	0	215	275	350
	GJG3030	300 x 300	23	210	270	350
	GJG3535	350 x 350	49	215	283	350
	GJG3020	300 x 200	-26	215	276	350
	GJG3525	350 x 250	-1	215	283	350
	GJG4030	400 x 300	23	215	275	350
	GJG4035	400 x 350	49	215	283	350
	GJGd30	Ø 300	12.5	215	278	350
	GJGd35	Ø 350	35.5	215	283	350
	GJGd40	Ø 400	58	205	280	350

MISURE RIFERITE A POSIZIONE PALO (X)

misure INDICATIVE espresse in cm. senza base o con tubo da interrare.  
su qualsiasi base + 15 cm.  
su base 25x25 + 7 cm.

SIZES RELATED TO POLE POSITION (X)

APPROXIMATE measures in cm. without base or underground tube.  
on any base + 15 cm.  
on the base 25x25 + 7 cm.

MANTOVANA / VALANCE



predisposizione chiusure laterali a richiesta  
equipped for side wall fitting on demand

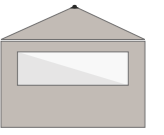

posizione del palo | pole position

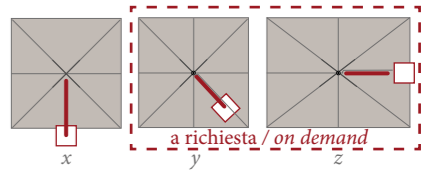

unione teli | canopy junction

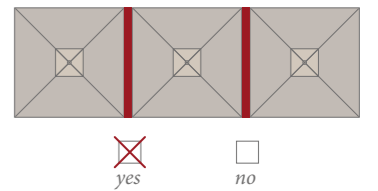

soffietto rialzato | raised bellow

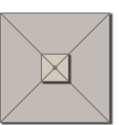

NON necessaria la rimozione arredi | NO furniture removal

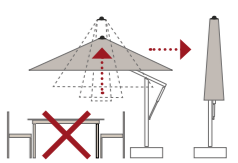

rotazione | rotation

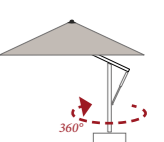

struttura predisposta per impianto elettrico a richiesta  
provided for electrical support on demand



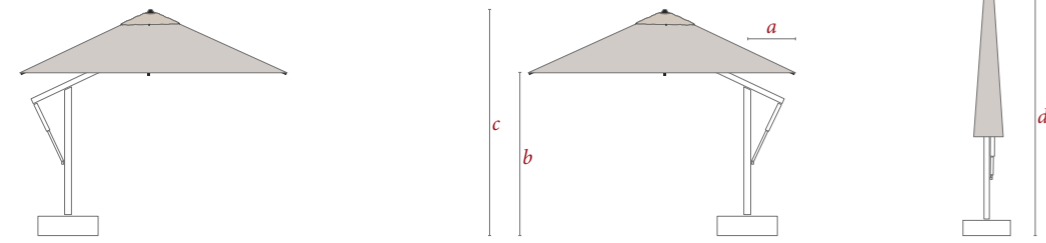

	MODELLO	cm.	a	b	c	d
	SUM3030	300 x 300	23	210	260	340
	SUM3535	350 x 350	49	215	270	340
	SUM4030	400 x 300	25	215	275	340
	SUM4040	400 x 400	42	215	275	365

misure INDICATIVE espresse in cm. senza base o con tubo da interrare.  
 su qualsiasi base + 15 cm.  
 su base 25x25 + 7 cm.  
 APPROXIMATE measures in cm. without base or underground tube.  
 on any base + 15 cm.  
 on the base 25x25 + 7 cm.

MANTOVANA / VALANCE

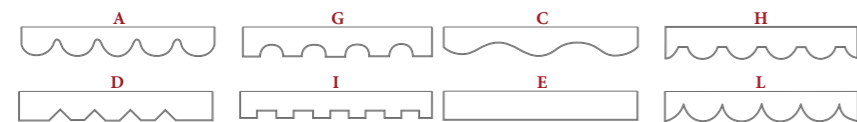

NON predisposizione chiusure laterali  
 NOT equipped for side wall fitting

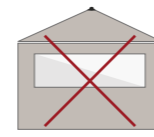

posizione del palo | pole position

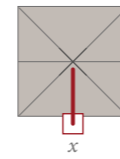

unione teli | canopy junction

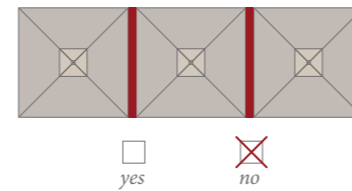

soffietto appoggiato | soft bellow

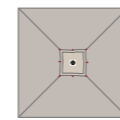

NON necessaria la rimozione arredi | NO furniture removal

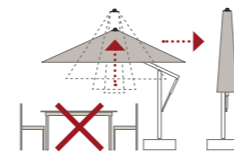

rotazione | rotation

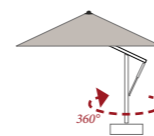

struttura NON predisposta per impianto elettrico  
 NOT provided for electrical support

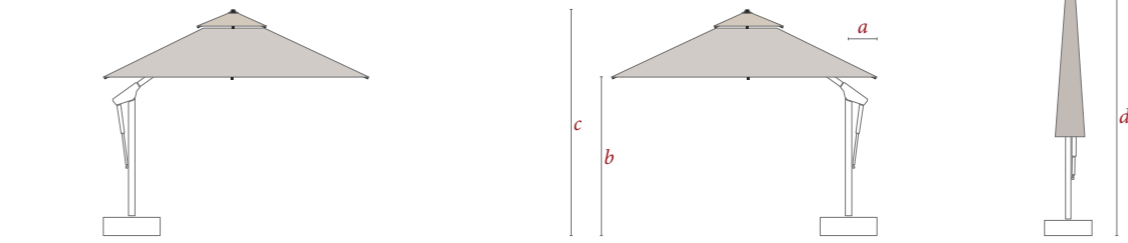

	MODELLO	cm.	a	b	c	d
	KNG4040	400 x 400	23	215	286	385
	KNG4545	450 x 450	58	215	298	385
	KNG4030	400 x 300	-17	215	281	385
	KNG4535	450 x 350	8	215	288	385
	KNG5040	500 x 400	33	215	298	385
	KNGd40	Ø 400	17	215	281	385
	KNGd50	Ø 500	64	215	296	385

MISURE RIFERITE A POSIZIONE PALO (X)  
 misure espresse in cm. senza base o con tubo da interrare.  
 su qualsiasi base + 15 cm.  
 su base 25x25 + 7 cm.

SIZES RELATED TO POLE POSITION (X)  
 APPROXIMATE measures in cm. without base or underground tube.  
 on any base + 15 cm.  
 on the base 25x25 + 7 cm.

MANTOVANA / VALANCE

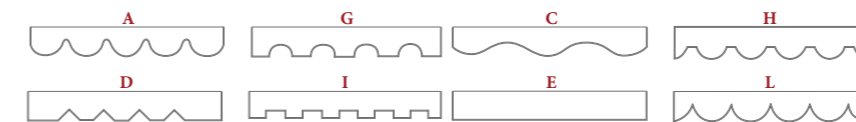

predisposizione chiusure laterali a richiesta  
 equipped for side wall fitting on demand

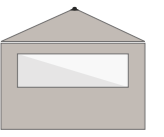

posizione del palo | pole position

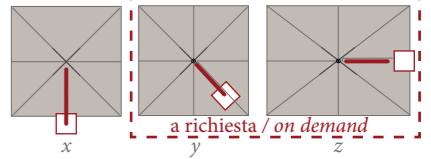

unione teli | canopy junction

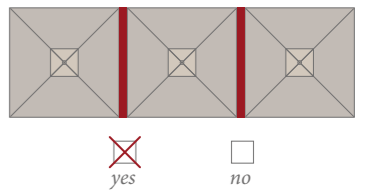

soffietto rialzato | raised bellow

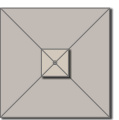

NON necessaria la rimozione arredi | NO furniture removal

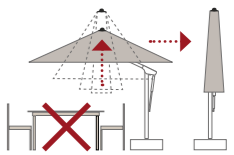

rotazione, inclinazione e regolazione | rotation, tilt and adjusting

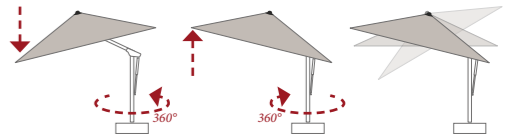

struttura predisposta per impianto elettrico  
 provided for electrical support



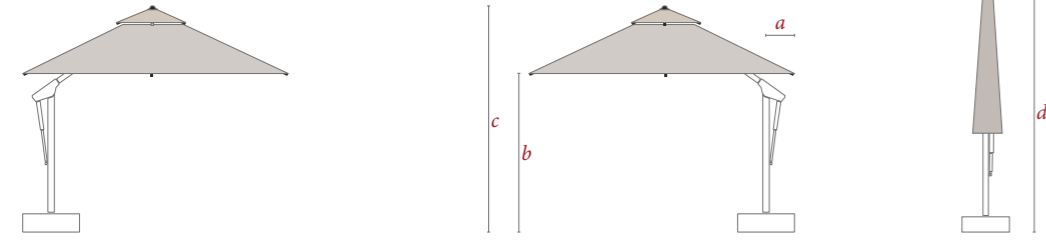

	MODELLO	cm.	a	b	c	d
	BKN3030	300 x 300	10	215	276	350
	BKN3535	350 x 350	29	215	283	350
	BKN4040	400 x 400	54	215	288	350
	BKN3525	350 x 250	-21	215	283	350
	BKN4030	400 x 300	-3.5	215	283	350
	BKNd40	Ø 400	39	215	288	350

**MISURE RIFERITE A POSIZIONE PALO (X)**  
 misure INDICATIVE espresse in cm. senza base o con tubo da interrare.  
 su qualsiasi base + 15 cm.  
 su base 25x25 + 7 cm.

**SIZES RELATED TO POLE POSITION (X)**  
 APPROXIMATE measures in cm. without base or underground tube.  
 on any base + 15 cm.  
 on the base 25x25 + 7 cm.

**MANTOVANA / VALANCE**

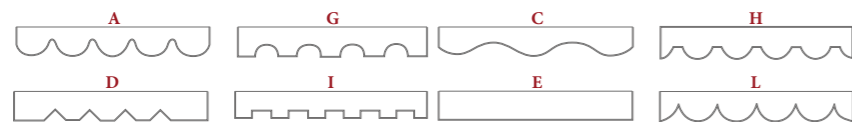

predisposizione chiusure laterali  
 equipped for side wall fitting

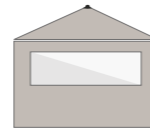

posizione del palo | pole position

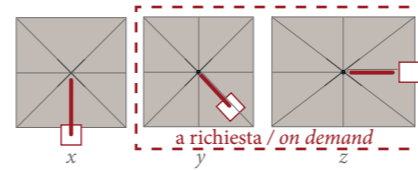

unione teli | canopy junction

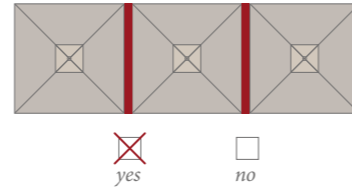

soffietto rialzato | raised bellow

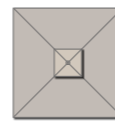

NON necessaria la rimozione arredi | NO furniture removal

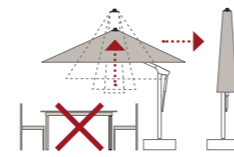

rotazione, inclinazione e regolazione | rotation, tilt and adjusting

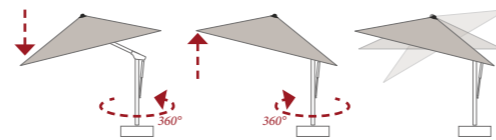

struttura predisposta per impianto elettrico  
 provided for electrical support

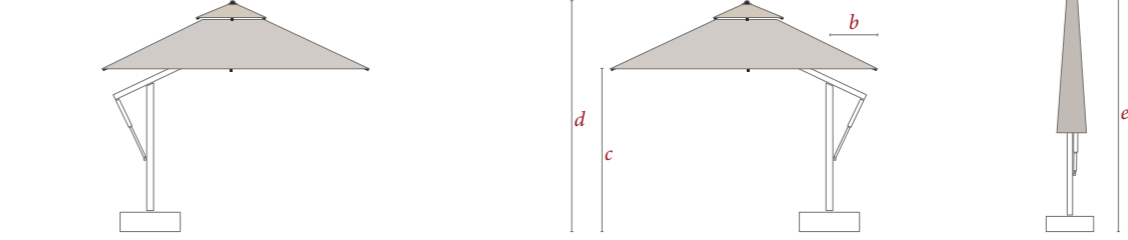

	MODELLO	cm.	b	c	d	e
	ONG2525	250 x 250	-1	215	273	350
	ONG3030	300 x 300	23.5	215	275	350
	ONG3535	350 x 350	49	215	283	350
	ONG3020	300 x 200	-26	215	276	350
	ONG3525	350 x 250	-1	215	283	350
	ONG4030	400 x 300	23	215	281	350
	ONG4035	400 x 350	49	215	288	350
	ONGd30	Ø 300	12.5	215	278	350
	ONGd35	Ø 350	35.5	215	283	350
	ONGd40	Ø 400	59	215	288	350

**MISURE RIFERITE A POSIZIONE PALO (X)**  
 misure INDICATIVE espresse in cm. senza base o con tubo da interrare.  
 su qualsiasi base + 15 cm.  
 su base 25x25 + 7 cm.

**SIZES RELATED TO POLE POSITION (X)**  
 APPROXIMATE measures in cm. without base or underground tube.  
 on any base + 15 cm.  
 on the base 25x25 + 7 cm.

**MANTOVANA / VALANCE**

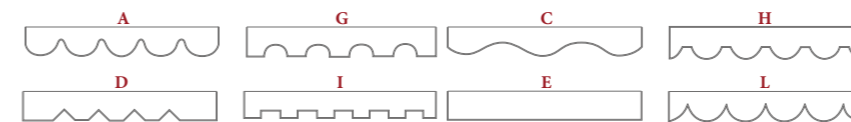

predisposizione chiusure laterali a richiesta  
 equipped for side wall fitting on demand

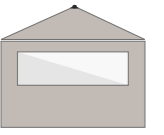

posizione del palo | pole position

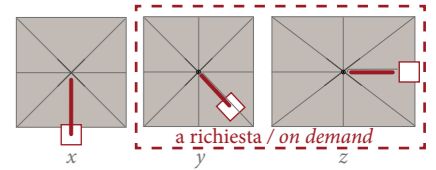

unione teli | canopy junction

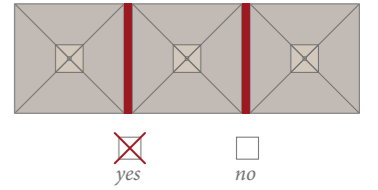

soffietto rialzato | raised bellow



NON necessaria la rimozione arredi | NO furniture removal

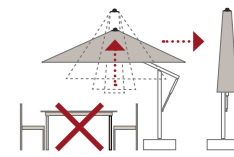



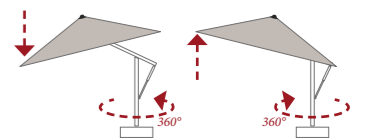





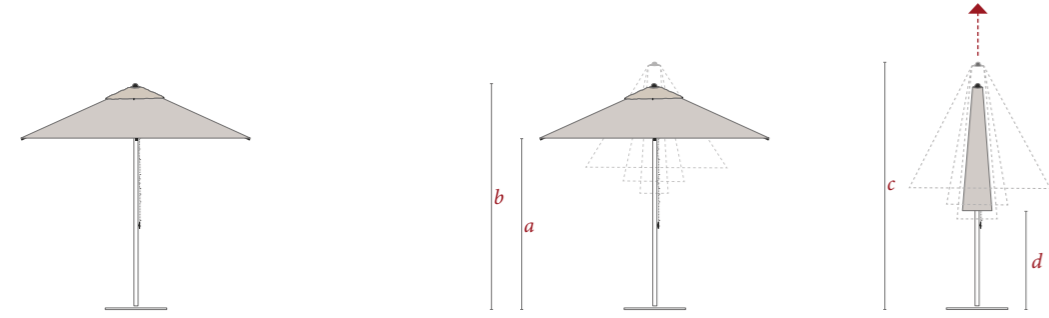



rotazione e inclinazione | rotation and tilt



struttura predisposta per impianto elettrico a richiesta  
 provided for electrical support on demand





MODELLO	cm.	a	b	c	d
 RPI2525	250 x 250	230	275	275	95
 RPI3030	300 x 300	230	275	275	65
 RPI3535	350 x 350	245	280	280	35
 RPI4040	400 x 400	245	300	300	20
 RPI3525	350 x 250	230	285	285	70
 RPI4030	400 x 300	235	280	280	30
 RPI4535	450 x 350	240	300	300	20
 RPI d30	Ø 300	230	265	265	110
 RPI d35	Ø 350	230	275	275	100
 RPI d40	Ø 400	230	280	280	80
 RPI d45	Ø 450	240	290	290	55

misure INDICATIVE espresse in cm. su qualsiasi base e tubo da interrare.  
APPROXIMATE measures in cm. on any bases or underground tube.

MANTOVANA / VALANCE



predisposizione chiusure laterali a richiesta  
equipped for side wall fitting on demand

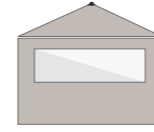

posizione del palo | pole position

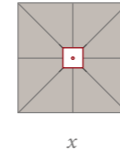

unione teli | canopy junction

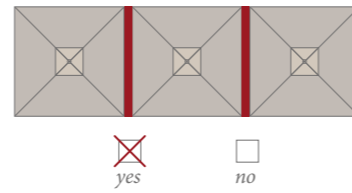

soffietto appoggiato | soft bellow

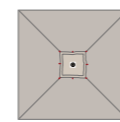

NON necessaria la rimozione arredi | NO furniture removal

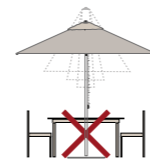



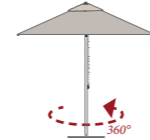

rotazione | rotation

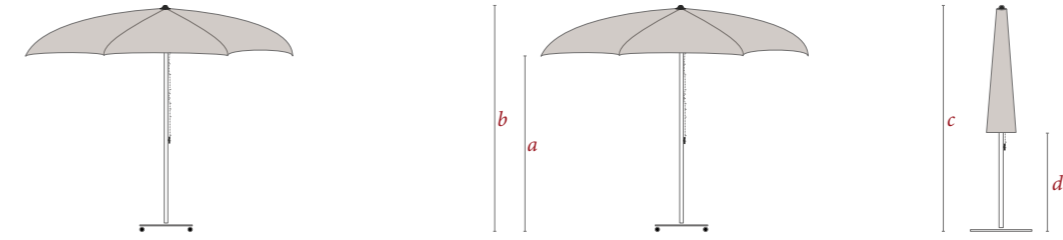

struttura NON predisposta per impianto elettrico  
NOT provided for electrical support



MODELLO	cm.	a	b	c	d
 BAYd25	Ø 250	230	250	250	125
 BAYd27	Ø 270	230	254	254	119
 BAYd30	Ø 300	230	265	265	115
 BAYd35	Ø 350	230	273	273	78

misure INDICATIVE espresse in cm. su qualsiasi base e tubo da interrare.  
APPROXIMATE measures in cm. on any bases or underground tube.

MANTOVANA / VALANCE



NON predisposizione chiusure laterali  
NOT equipped for side wall fitting

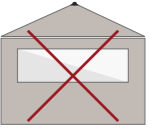

posizione del palo | pole position

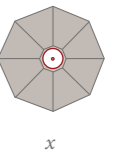

unione teli | canopy junction

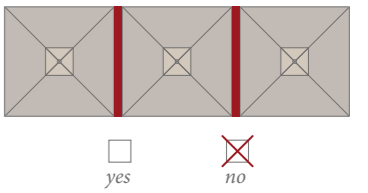

soffietto | bellow

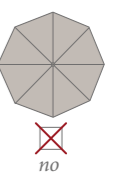

NON necessaria la rimozione arredi | NO furniture removal



rotazione | rotation



struttura NON predisposta per impianto elettrico  
NOT provided for electrical support





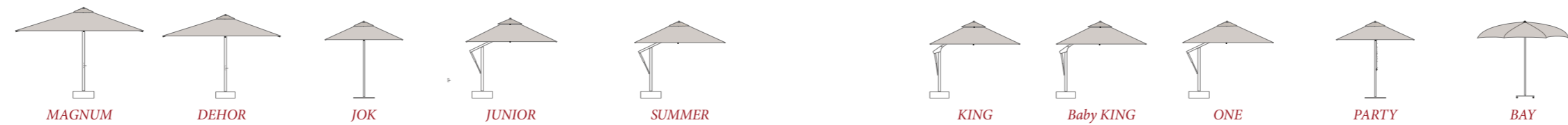

	MAGNUM	DEHOR	JOK	JUNIOR	SUMMER	KING	Baby KING	ONE	PARTY	BAY	
PALO LATERALE	-	-	-	•	•	•	•	•	-	-	SIDE POLE
PALO CENTRALE	•	•	•	-	-	-	-	-	•	•	CENTRAL POLE
STRUTTURA IN ALLUMINIO	•	•	•	•	•	•	•	•	•	•	ALLUMINIUM
MISURE PALO	Ø 100x3 mm.	Ø 85x3 mm.	Ø 60x2 mm.	90x90x2.5 mm.	90x90x2.5 mm.	117x106x3 mm.	117x106x3 mm.	104x94x3 mm.	Ø 50x2 mm.	Ø 50x2 mm.	SHAFT
MISURE BRACCIO	-	-	-	80x50x2 mm.	80x50x2 mm.	105x73x3 mm.	105x73x3 mm.	85x69x2 mm.	-	-	SIDE ARMS
MISURE STECCHE	45x20x2 mm.	35x20x2 / 45x20x2 mm.	35x20x2 mm.	25x20x2 / 35x20x2 mm.	25x20x2 / 35x20x2 mm.	35x20x2 mm.	35x20x2 mm.	30x20x2 mm.	25x20x2 / 35x20x2 mm.	30x20x2 mm.	RIBS
STECHE DIAGONALI RINFORZATE	•	•	-	-	-	-	-	-	-	-	REINFORCED DIAGONALS
NUMERO STECCHE	8/10/12	8	8	8	8	8	8	8	8	8	NUMBER OF RIBS
BULLONERIA INOX	•	•	•	•	•	•	•	•	•	•	STAINLESS STEEL NUTS, BOLTS, SCREWS
VERNICIATURA CON POLVERI TERMOINDURENTI	•	•	•	•	•	•	•	•	•	•	THERMOSETTING POWDER COATS
APERTURA/CHIUSURA TELESCOPICA	•	•	•	-	-	-	-	-	-	-	TELESCOPIC OPENING/CLOSING SYSTEM
ORIENTAMENTO DEL TELO	-	-	-	-	-	•	•	•	-	-	CANOPY TILT
SOFFIETTO APPOGGIATO	•	•	•	-	•	-	-	-	•	-	SOFT BELLOW
SOFFIETTO RIALZATO	-	-	-	•	-	•	•	•	-	-	RAISED BELLOW
MANOVELLA	•	•	•	•	•	•	•	•	-	-	CRANK
CUSTODIA ANTIGELIVA CON CERNIERA	•	•	•	•	•	•	•	•	•	•	WINTER STORAGE COVER
PREDISPOSIZIONE CHIUSURE LATERALI	•	•	•	-	-	•	•	-	-	-	EQUIPPED FOR SIDE WALL FITTING
UNIONE TELI	•	•	•	•	-	•	•	•	•	-	CANOPY CONNECTORS
PESO	80/120 kg.	50/80 kg.	20 kg.	30kg.	30kg.	55 kg.	55 kg.	35 kg.	18kg.	16 kg.	WEIGHT
STRUTTURA PREDISPOSTA PER IMP. ELETTRICO	•	•	-	-	-	•	•	-	-	-	STRUCTURE ARRANGED FOR ELECTRICAL SUPPORT

**Art Direction**  
www.poggesi.it

**Design & page Layout**  
www.valerianogrossi.it

**Photography**  
www.valerianogrossi.it

**Print**  
2017

**Ombrellificio Poggesi**

Via Fiorentina, 70  
50063 Figline Valdarno (FI)

Phone +39 055 951946 / +39 055 9544814

Fax +39 055 958342

www.poggesi.it - info@poggesi.it



**Ombrellificio Poggesi si riserva di apportare modifiche al design e alla tecnologia dei prodotti nell'interesse del cliente.**  
Ombrellificio Poggesi reserves the right to make changes to the design and technology of the products in the interest of the customer.



MADE IN FLORENCE