



VALPORTEC
PUERTAS TÉCNICAS

- | | | |
|-------------------------------------|-------------------------------|-------------------------------|
| · <i>Portes techniques</i> | · Technical doors | · Puertas técnicas |
| · <i>Portes coupe-feu</i> | · Fire doors | · Puertas cortafuego |
| <i>EI 30</i> | EI 30 | EI 30 |
| <i>EI 30 encadrement métallique</i> | EI 30 metallic frame | EI 30 marco metálico |
| <i>EI 30 affleurante</i> | EI 30 flush | EI 30 enrasada |
| <i>EI 45</i> | EI 45 | EI 45 |
| <i>EI 60</i> | EI 60 | EI 60 |
| · <i>Portes isophoniques</i> | · Isophonic doors | · Puertas isofónicas |
| · <i>Portes anti-pincement</i> | · Finger-guard doors | · Puertas antipinzamientos |
| · <i>Portes affleurantes</i> | · Flush-fitted doors | · Puertas enrasadas |
| · <i>Certifiées et garanties</i> | · Certificates and guarantees | · Certificadas y garantizadas |

Hoteles · Colegios · Residencias · Museos
 Hospitales · Teatros · Centros Sociales

Hotels · Colleges · Residences · Museums
 Hospitals · Theatres · Social Centres

Hôtels · Écoles · Foyers · Musées
Hôpitaux · Théâtres · Centres Sociaux





*technique
(et design)*

**technical
(and design)**

**técnica
(y diseño)**

Nos portes techniques certifiées garanties assurent à tous nos clients le standard de qualité nécessaire afin de remplir les exigences techniques et de qualité indispensables.

Nous vous offrons des portes techniques avec d'excellentes prestations, combinant la technique la plus innovante et la créativité.

Ceci permet d'obtenir un large éventail de modèles et de finitions. Les matériaux sont utilisés pour obtenir des produits qui s'adaptent aux besoins particuliers de chaque client, comme les portes techniques, qui peuvent être ignifuges (portes coupe-feu), ou avec une isolation phonique de jusqu'à 30 dB, par exemple.

Portes techniques : garantie, qualité, design, variété, prestations et sécurité.

Our technical doors with guarantee certification ensure that all of our clients get the necessary quality standard to comply with the essential technical and quality requirements.

We supply technical doors with excellent features, combining the most innovative techniques with creativity.

This means we have a great variety of models and finishes to offer products that adapt to the specific needs of each client, like technical doors that can be flame retardant (fire doors); or with sound attenuation of up to 30 dB, for example.

Technical doors: guarantee, quality, design, variety, features and safety.

Nuestras puertas técnicas con certificación de garantía aseguran a todos nuestros clientes el estándar de calidad necesario para que cumplan con los requisitos técnicos y de calidad imprescindibles.

Suministramos puertas técnicas de excelentes prestaciones combinando la técnica más innovadora con la creatividad.

Esto permite una gran variedad de modelos y acabados. Los materiales se utilizan para ofrecer productos que se adaptan a las necesidades particulares de cada cliente, como puertas técnicas, que pueden ser ignífugas (puertas cortafuegos); o con atenuación acústica de hasta 30 dB, por ejemplo.

Puertas técnicas: garantía, calidad, diseño, variedad, prestaciones y seguridad.





***vosre projet,
une réalité***

**your project,
a reality**

**tu proyecto,
una realidad**

Hôtels, écoles, foyers, hôpitaux, musées, théâtres, centres sociaux, centres commerciaux et grands établissements publics exigent tous une finition professionnelle qui conjugue la technique et l'esthétique.

Notre défi est de garantir la qualité des portes techniques et d'adapter leurs caractéristiques à la philosophie de chaque bâtiment, en fonction des mesures et des exigences du client.

Hotels, colleges, residences, hospitals, museums, theatres, social centres, shopping centres and large public works installations require a professional finish that unifies technique and aesthetics.

Our challenge is to guarantee the quality of the required technical doors and to tailor their characteristics to the philosophy of each building as per the client's measurements and requirements.

Hoteles, colegios, residencias, hospitales, museos, teatros, centros sociales, centros comerciales y grandes instalaciones de obra pública necesitan un acabado profesional que aune técnica y estética.

Nuestro reto es garantizar la calidad de las puertas técnicas que se necesiten y adecuar sus características a la filosofía de cada edificio, según las medidas y requerimientos del cliente.



puertas abatibles,
cerco oculto

swing doors,
hidden frame

*portes battantes,
clôture cachée*

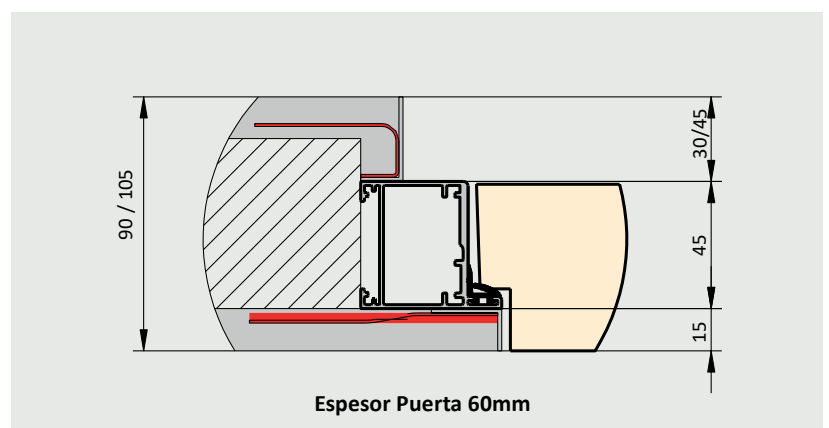
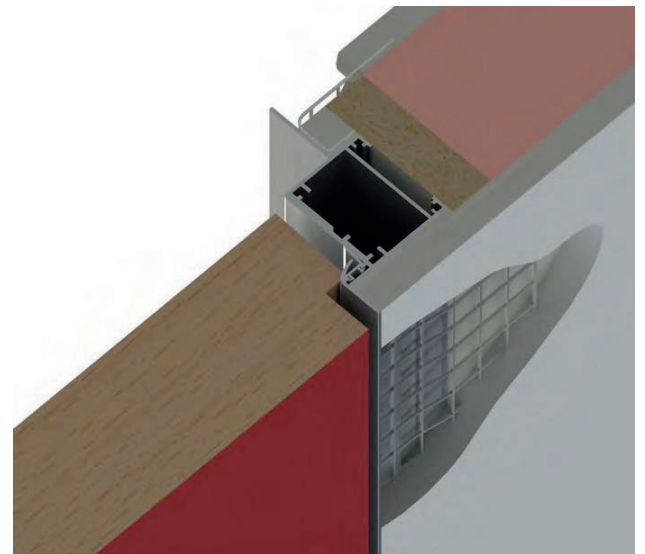
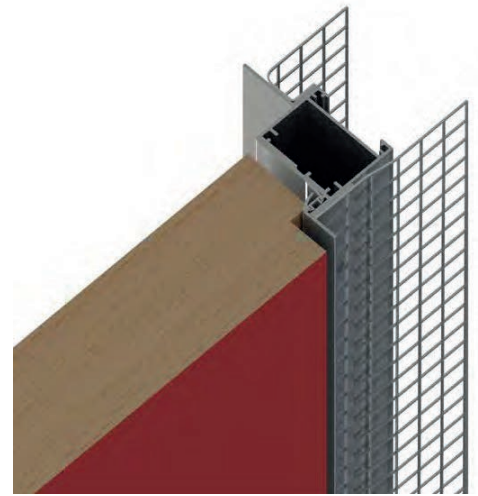

MARCO PARED PYL

FRAME DRYWALL



Aluminio
Aluminium

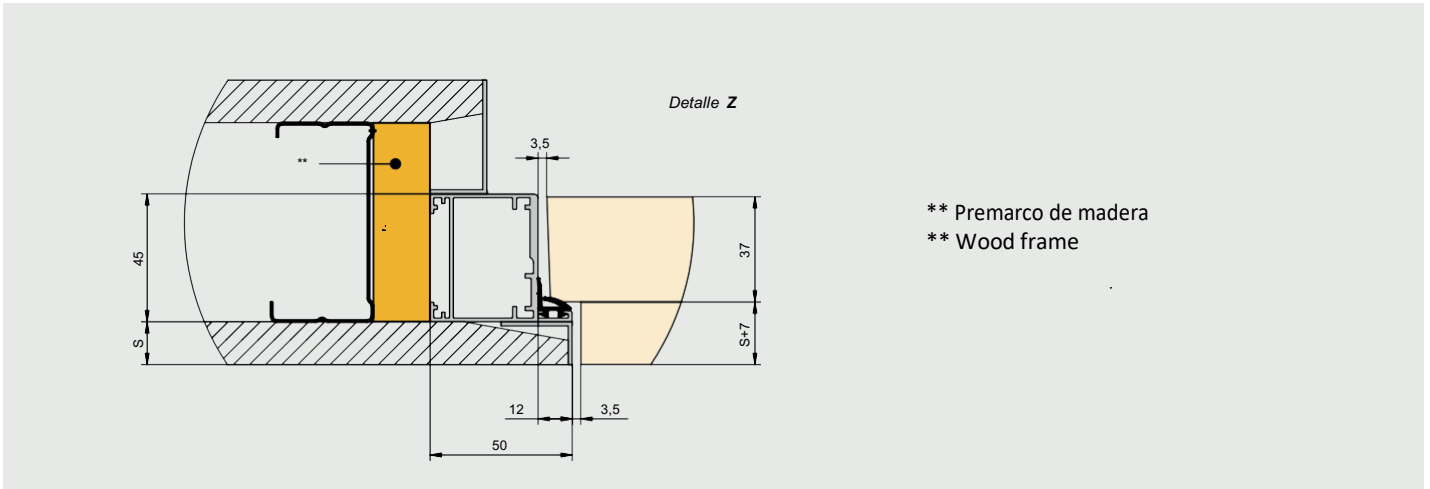
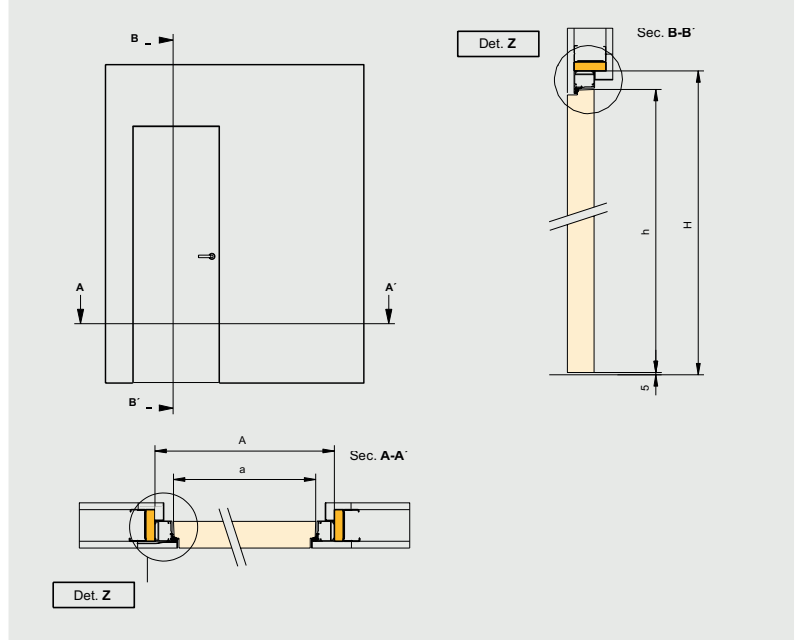

Opciones

Options

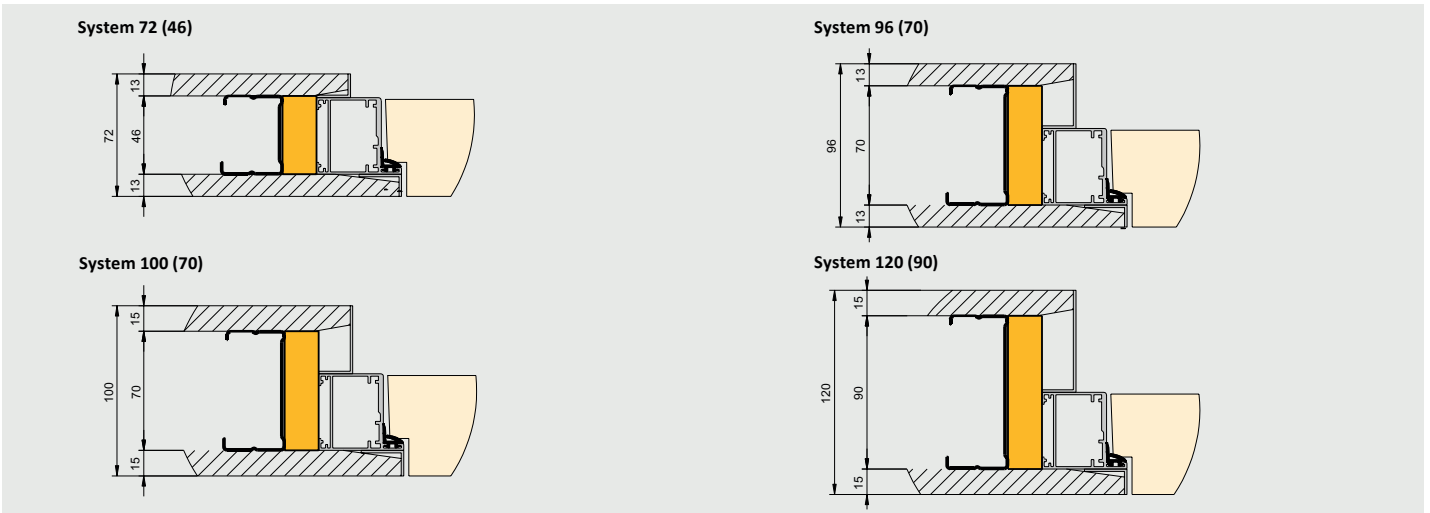

MARCO PARED PANELADA

FRAME PANELED WALL

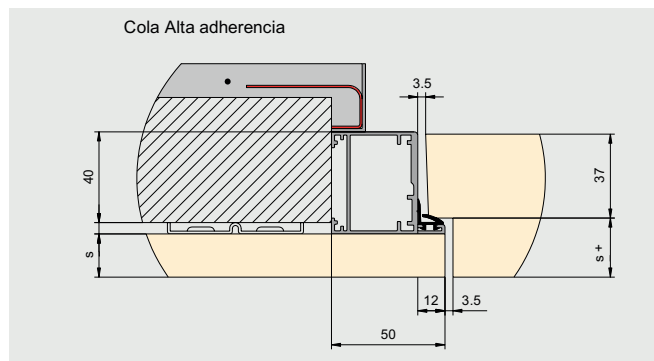
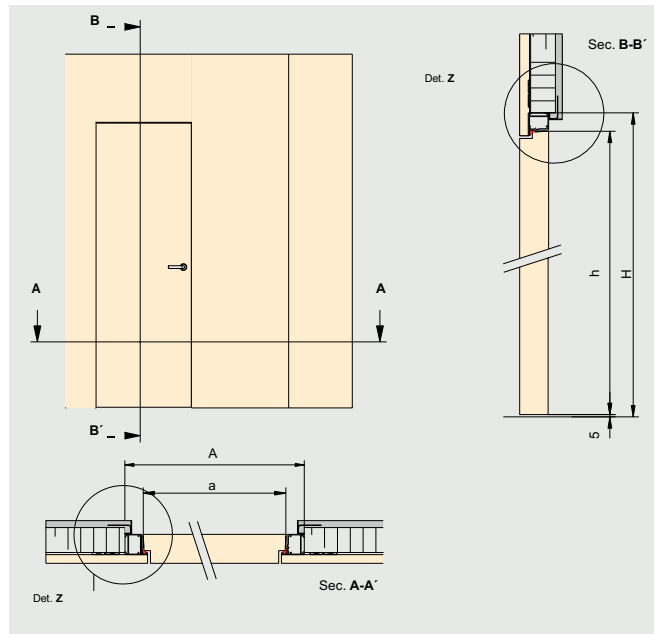

Opciones

Options

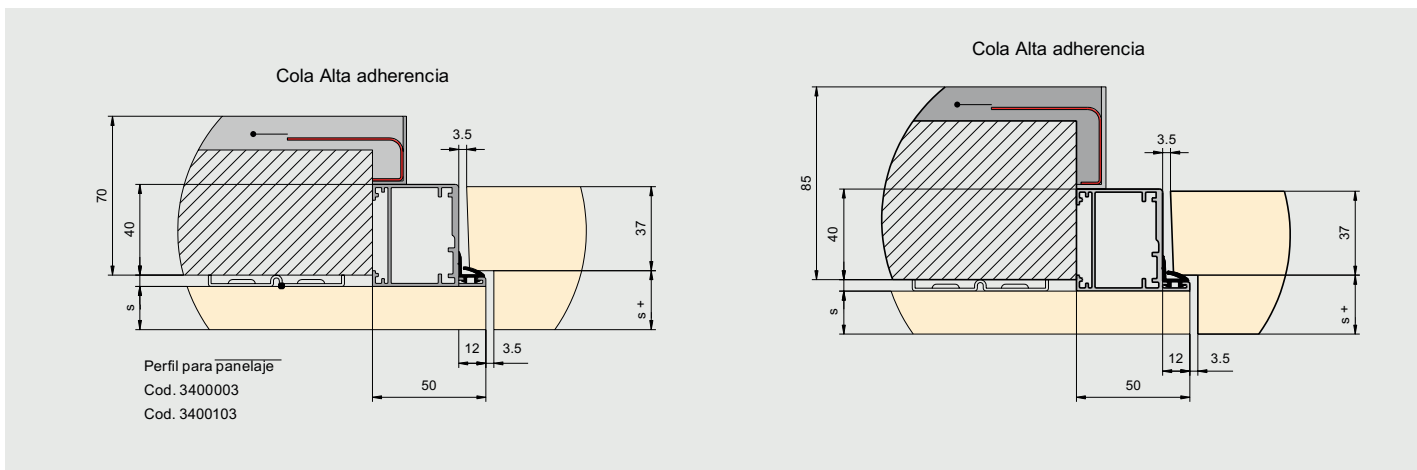





***spécial les écoles
et les jardins
d'enfants, surtout
la sécurité***

**special
kindergartens
and schools,
safety is a priority**

**especial colegios
y guarderías, ante
todo seguridad**

Notre système de porte repose sur le remplacement des charnières classiques pour le système exclusif et breveté charnières fixation de la feuille sur le châssis dans le côté supérieur.

Our door system is based on the substitution of traditional hinges by an exclusive patented concealed hinge system. These concealed hinges fix the door leaf to frame on top and bottom, not on the side.

Nuestro sistema de puertas se basa en la sustitución de las tradicionales bisagras por un sistema de pernios exclusivo y patentado, que fija la hoja al marco en la parte lateral superior.

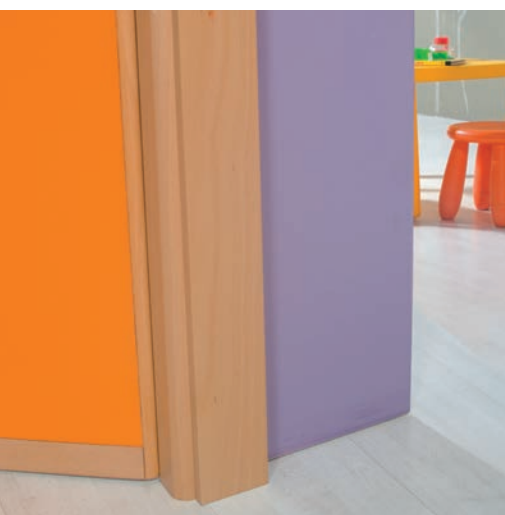

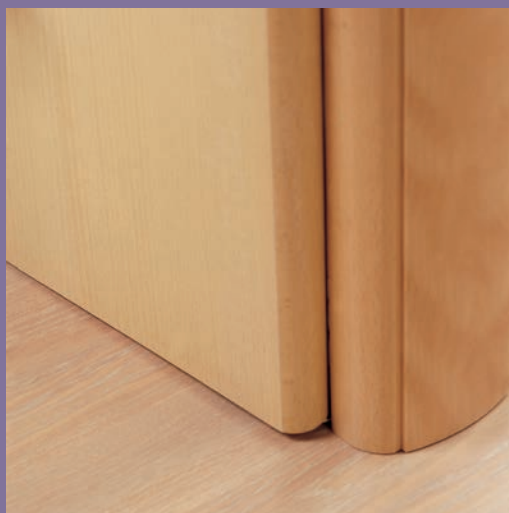

imagina
un acabado...

imagine
a finish...

*imaginez
une finition...*

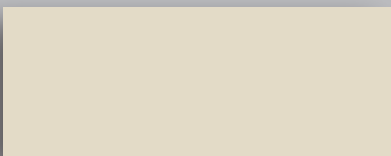
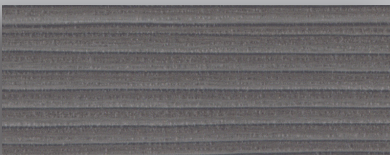
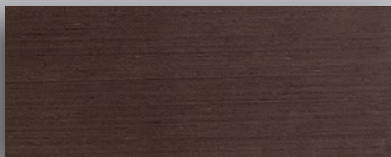
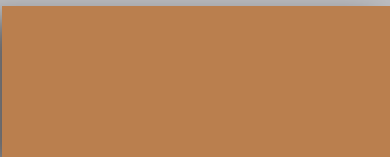

Imagina calidades y acabados de ensueño fácilmente realizables con nuestras soluciones profesionales.

Contrata con nosotros tus necesidades específicas y otros elementos de alto valor añadido para dotar de mayor calidad a tus proyectos.

Aunar técnica y estética es nuestro objetivo.

Imagine dream qualities and finishes, easily carried out with our professional solutions.

Contract your specific requirements with us, as well as other high added value elements to give greater significance to your projects. Unifying technique and aesthetics is our goal.

Imaginez des qualités et des finitions de rêve facilement réalisables grâce à nos solutions professionnelles

Consultez-nous vos besoins spécifiques et d'autres éléments à haute valeur ajoutée pour doter vos projets d'une plus grande portée.

Notre but: marier la technique et l'esthétique.



***notre
expérience,
notre garantie***

**we are
backed by our
experience**

**nuestra
experiencia
nos avala**

Depuis des années, nous réalisons des portes techniques pour tous types de bâtiments. Nous avons l'expertise et la rigueur nécessaires pour la satisfaction absolue de nos clients et surtout, nous prenons soin de la technique et de l'esthétique de vos projets, en veillant particulièrement aux caractéristiques et aux besoins techniques. Contactez-nous et exprimez vos besoins. Nous sommes là pour vous écouter et vous aider. Nous vous proposons les meilleures portes techniques parmi une vaste gamme de modèles et de spécificités (blindages, coupe-feu, isolantes acoustiques...).

We have been developing technical doors for all types of buildings for many years now. We have the professionals and the rigour required to reach total client satisfaction and, above all, we take care of the technique and the aesthetics of your project, taking the characteristics and technical needs into consideration. Contact us and tell us about your concerns. We listen and help you. We provide the best technical doors within a wide range of models and specifications (reinforced, fire, sound proof...).

Desarrollamos desde hace años puertas técnicas para todo tipo de edificios. Poseemos la profesionalidad y rigor necesarios para llegar a alcanzar la satisfacción absoluta de nuestros clientes y cuidamos, por encima de todo, la técnica y estética de sus proyectos, en atención a las características y necesidades técnicas. Contacta con nosotros y cuéntanos tus inquietudes. Te escuchamos y ayudamos. Aportamos las mejores puertas técnicas entre una amplia gama de modelos y especificidades (blindajes, cortafuegos, aislantes acústicas...).

**Tenemos la puerta
que necesitas**

**We have the door
you need**

***Nous avons la porte
dont vous avez besoin***

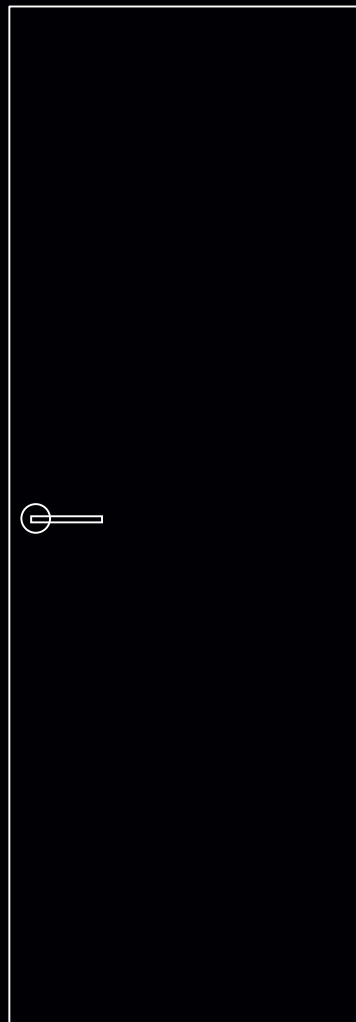

VALPORTEC
PUERTAS TÉCNICAS

C/ Pujadeta del Sord, 72
46960 Aldaia (Valencia)
SPAIN
T. 96 152 69 35
info@valportec.com
www.valportec.com